

A. フレーム関係 / Machine body / Maschinengehäuse /
 Corps de la machine / Cuerpo de la máquina

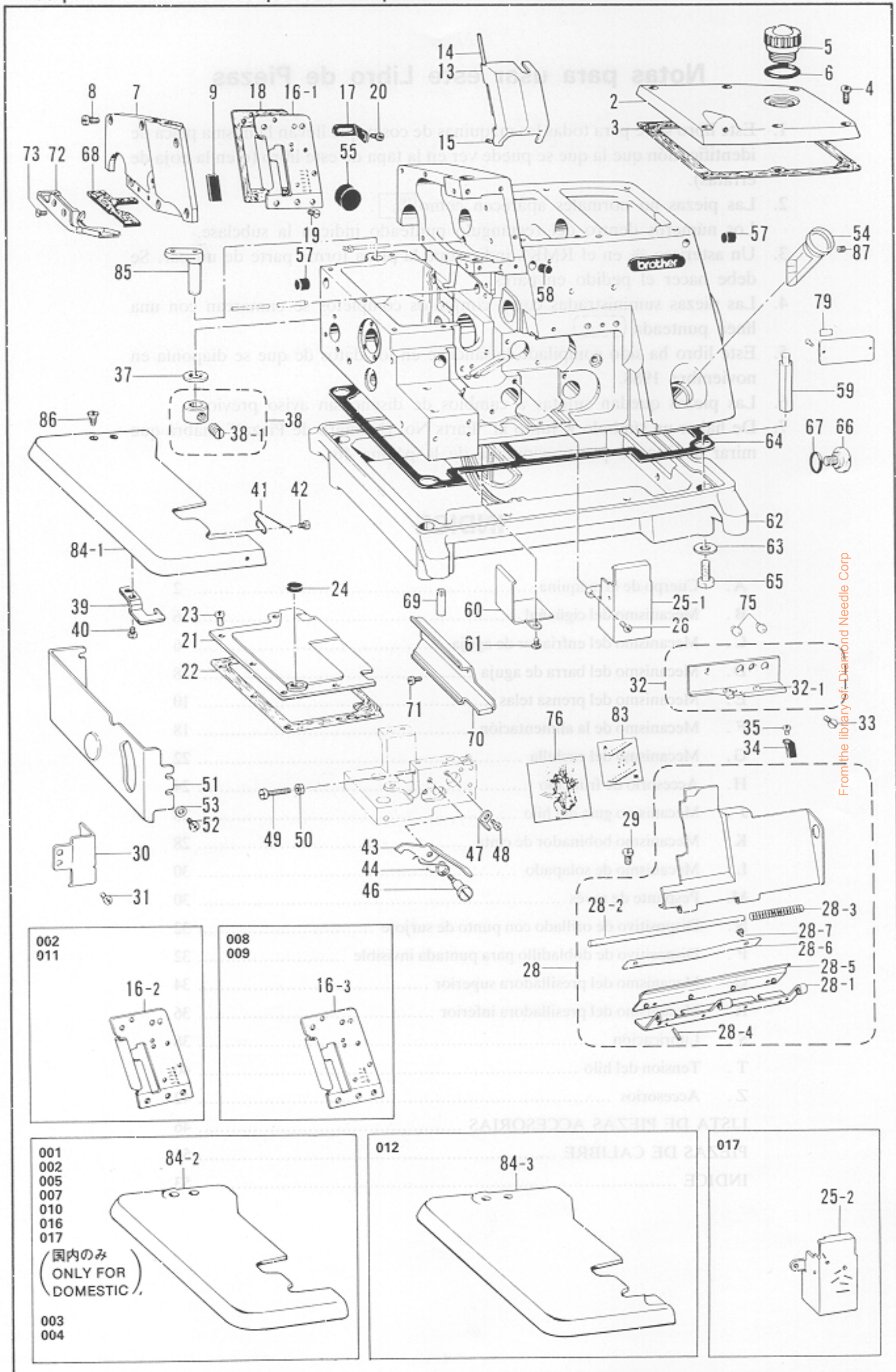

A. フレーム関係 / Machine body / Maschinengehäuse /
Corps de la machine / Cuerpo de la máquina

REF.NO.	CODE	Q'TY	ヒンメイ	NAME OF PARTS	RMKS
2	146419001	1	ウツカハ-	TOP COVER	
3	146420000	1	ハツキン	PACKING	
4	062681412	6	ナヘコ437-40X14	SCREW 437X14	
5	146421000	1	オイルクチキヤツフ	OIL FEEDING HOLE CAP	
6	113589001	1	オイルマトハツキン	PACKING	
7	146422001	1	ソクメンカハ-	COVER FOR NEEDLE DRIVING MECHANISM	
8	062680712	6	ナヘコ437-40X7	SCREW 437X7	
9	143992001	1	ゴムフタ	RUBBER CAP	
13	146425001	1	メンイタカハ-	FACE PLATE COVER	
14	146426000	1	ヒンジシク	HINGE SHAFT	
15	146427001	1	アタメネシ3.18クホミ	SCREW 3.18	
16-1	146428001	1	メンイタクミ<シ>ヌイヨウ>	FACE PLATE ASSEMBLY <FOR PLAIN STITCHING>	
16-2	146706001	1	メンイタクミ<ハ>ルキヨウ>	FACE PLATE ASSEMBLY <FOR BULKY>	
16-3	146430001	1	メンイタクミ<ラ>フラーヨウ>	FACE PLATE ASSEMBLY <FOR RUFFLING>	
17	146432001	1	トメイタハネ	STOPPER SPRING PLATE	
18	146433000	1	ハツキン	FACE PLATE PACKING	
19	102843004	3	サラネシ3.57	SCREW 3.57	
20	062670612	2	ナヘコ357-40X6	SCREW 357X6	
21	146708000	1	オクリタイカハ-	COVER FOR FEED MECHANISM	
22	146709000	1	ハツキン	PACKING	
23	*	5	ナヘコ437-40X7	SCREW 437X7	
24	111486001	1	クロスプレートクッション	CLOTH PLATE CUSHION	
25-1	146436001	1	ウチカハ-	INSIDE COVER	
25-2	S11669001	1	ウチカハ-<ソフトチェンヨウ>	INSIDE COVER <FOR SOFT CHAIN>	
26	062670612	2	ナヘコ357-40X6	SCREW 357X6	
28	148991001	1	マエカハークミ	FRONT COVER ASSEMBLY	
28-1	146440001	1	マエカハ-ヒンジ	FRONT COVER HINGE	
28-2	146441000	1	マエカハ-ヒンジシク	FRONT COVER HINGE SHAFT	
28-3	146442001	1	マエカハ-ハネ	FRONT COVER SPRING	
28-4	047140842	1	スプリングピン1.4X8	SPRING PIN 1.4X8	
28-5	148984001	1	ヒンジカハ-	HINGE COVER	
28-6	152194001	1	ヒンジカハ-オサイイタ	HINGE COVER PRESSER PLATE	
28-7	062670412	2	ナヘコ357-40X4	SCREW 357X4	
29	060680512	2	ハインド437-40X5	SCREW 437X5	
30	146712001	1	マエカハ-アンナイイタ	FRONT COVER GUIDE PLATE	
31	062670612	2	ナヘコ357-40X6	SCREW 357X6	
32	146713001	1	マエカハ-ササイクミ	SUPPORTER FOR FRONT COVER ASSEMBLY	
32-1	146924000	2	スレットフツシユ	THREAD BUSHING	
33	117160001	2	サラネシ4.37	SCREW 4.37	
34	154829001	1	マエカハ-トメイタハネ	STOPPER SPRING PLATE FOR FRONT COVER	
35	123185001	1	マルヒラネシ3.57X4.5	SCREW 3.57X4.5	
37	141183000	1	クロスプレートシート	CLOTH PLATE SHEAT	
38	181969003	1	セツトカラークミ	SET COLLAR ASSEMBLY	
38-1	101706001	2	トメネシ6.35	SCREW 6.35	
39	146449001	1	クロスプレートトメイタ	CLOTH PLATE SUPPORTER PLATE	
40	060670512	2	ハインド357-40X5	SCREW 357X5	
41	146450001	1	クロスプレートトメシハネ	SPRING	
42	060670512	1	ハインド357-40X5	SCREW 357X5	
43	146451001	1	クロスプレートトメテコ	CLOTH PLATE LEVER	
44	146452001	1	トメテコトメシハネ	SPRING	
46	146453001	1	ダンネシ3.57	STUD SCREW 3.57	
47	146454001	1	トメテコトメツハ	CLOTH PLATE LEVER STOPPER	
48	062670612	1	ナヘコ357-40X6	SCREW 357X6	
49	062671412	1	ナヘコ357-40X14	SCREW 357X14	
50	021670202	1	ナット2シユ3.57	NUT 3.57	
51	146717101	1	クロスプレートシタ	CLOTH PLATE (LOWER)	
52	062680712	4	ナヘコ437-40X7	SCREW 437X7	
53	100645003	4	ワッシャー	WASHER	
54	148084001	1	オイルゲージマト	OIL GAUGE WINDOW	
55	140066001	1	メクラセン	OIL CAP	
57	146315000	2	メクラセン	OIL CAP	
58	140421001	1	メクラセン	OIL CAP	

From the library of: Diamond Needle Corp

A. フレーム関係 / Machine body / Maschinengehäuse /
 Corps de la machine / Cuerpo de la máquina

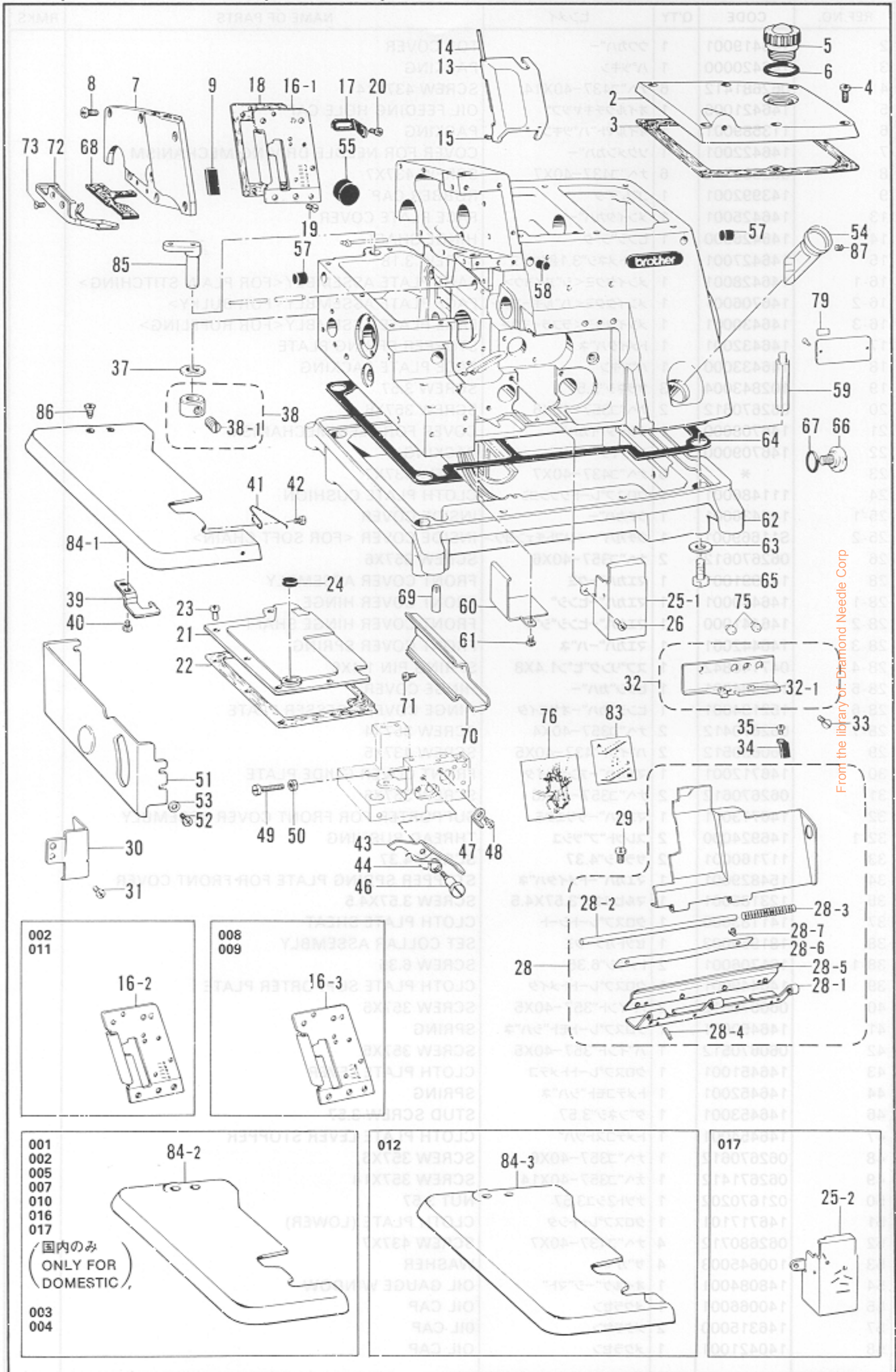

From the library of Diamond Needle Corp

A. フレーム関係/Machine body/Maschinengehäuse/
Corps de la machine/Cuerpo de la máquina

REF.NO.	CODE	Q'TY	品名	NAME OF PARTS	RMKS
59	151059001	4	ホンタイシチュウ	MACHINE BODY LEG	
60	146457001	1	シキリイタ	OIL STOPPER PLATE	
61	062670612	2	ナヘ"コ357-40X6	SCREW 357X6	
62	S03887201	1	アブ"ラウケ	OIL RESERVOIR	
63	159476000	4	サ"カ"ネ	WASHER	
64	151060000	1	ハ"ツキン	PACKING	
65	017771612	4	ボ"ルト6.35X16	BOLT 6.35X16	
66	110641002	1	ダ"ンネジ"9.52	STUD SCREW 9.52	
67	109203001	1	Oリング"	O RING	
68	159640000	1	フェルト	FELT	
69	118550001	4	ミゾ"ツキピン	DOWEL PIN	
70	146460001	1	クロスプレートヌノアンナイL	CLOTH GUIDE (LARGE)	
71	062670612	2	ナヘ"コ357-40X6	SCREW 357X6	
72	159639001	1	クロスプレートヌノアンナイS	CLOTH GUIDE (SMALL)	
73	108960002	2	サラネジ"3.57	SCREW 3.57	
75	*	2	オイルニカ"シク"チ	OIL CAP	
76	146718001	1	イトオシセツメイイタ <3ホンイトヨウ>	THREADING DIAGRAM <3 THREADS>	
76	146719001	1	イトオシセツメイイタ <2ホンイトヨウ 004.005>	THREADING DIAGRAM <2 THREADS,004.005>	
76	S13676001	1	イトオシセツメイイタ <ソフトチェンヨウ>	THREADING DIAGRAM <FOR SOFT CHAIN>	
79	*	1	シヨウラヘ"ル	LABEL	
83	147943001	1	ルーパ"イトチヨクセツラヘ"ル <3ホンイトヨウ>	LABEL <3 THREADS>	
84-1	S09323001	1	クロスプレート	CLOTH PLATE	
84-2	S09324001	1	クロスプレート	CLOTH PLATE	
84-3	S11099001	1	クロスプレート	CLOTH PLATE	
85	143374001	1	クロスプレートササエシ"ク	CLOTH PLATE SUPPORTER SHAFT	
86	100032003	2	サラネジ"4.37	SCREW 4.37	
87	014680422	1	ア"ナトメネジ"4.37クホ"ミ	SCREW 4.37	

From the library of: Diamond Needle Corp

B. 駆動軸関係/Crank shaft mechanism/Kurbelwelle/
 Mécanisme du vilebrequin/Mecanismo del cigüeñal

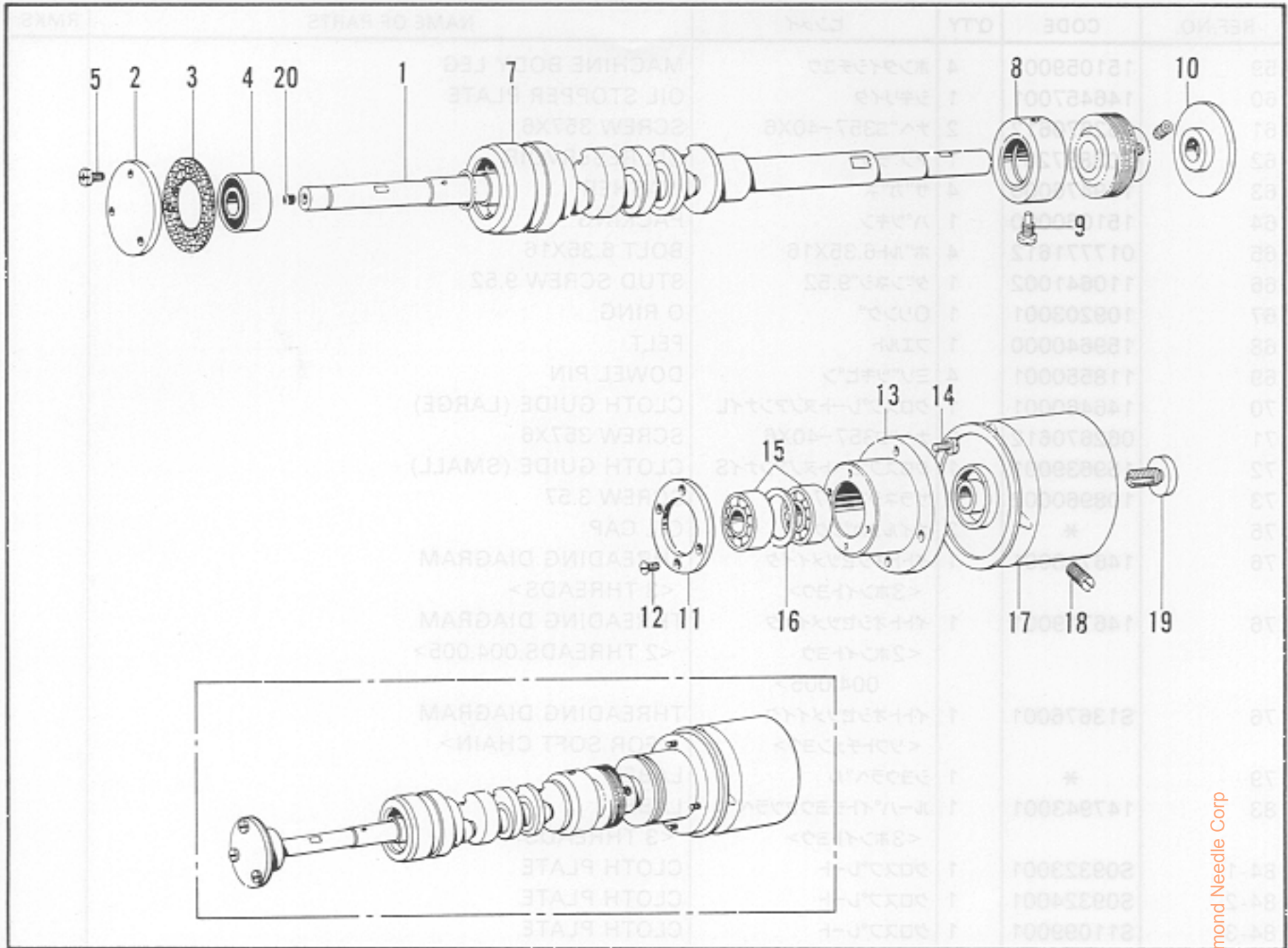

C. 針冷却装置/Needle cooler/Nadelkühlungsvorrichtung/
 Mécanisme du refroidisseur d'aiguille/Mecanismo del enfriador de aguja

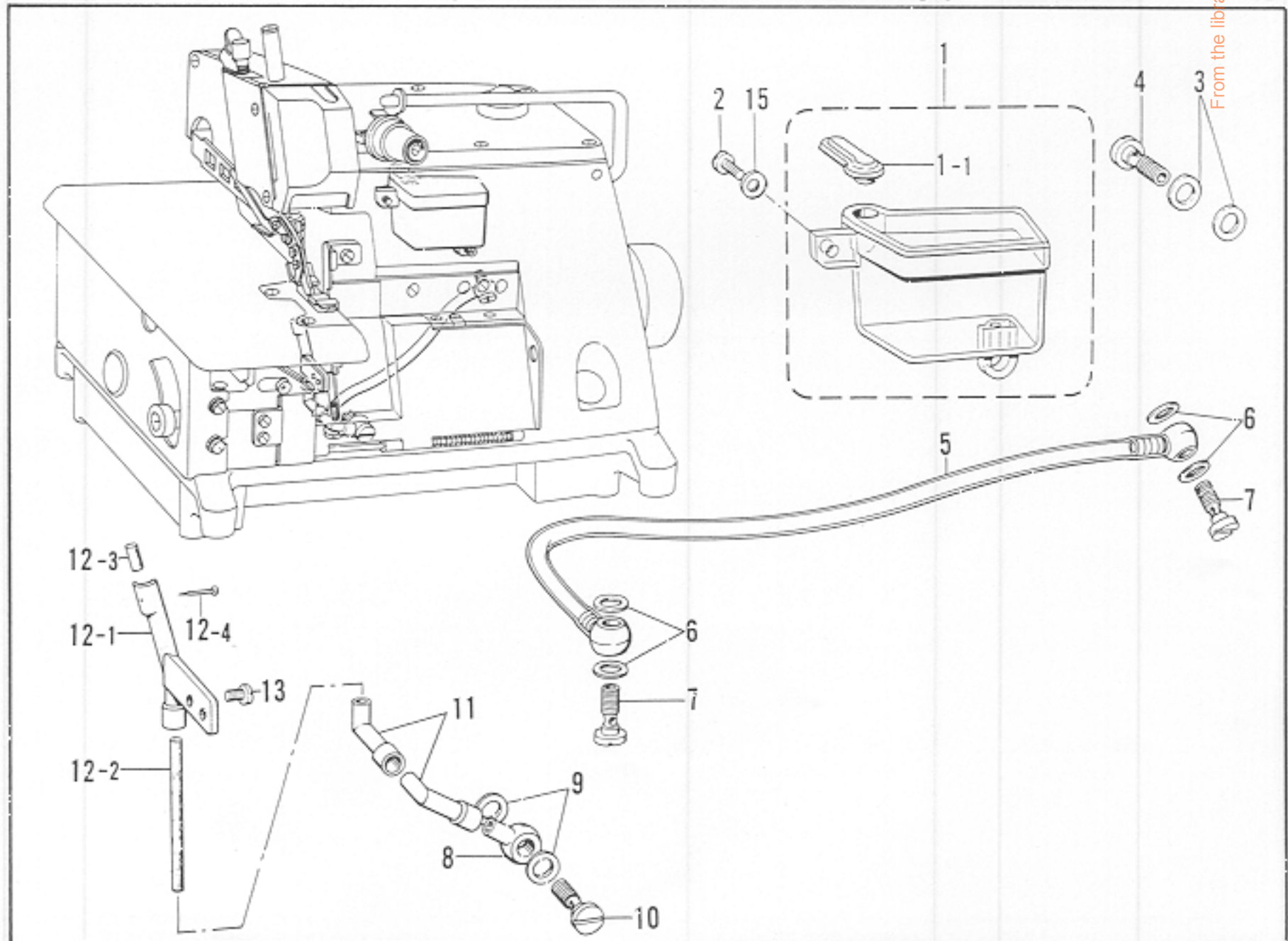

From the library of: Diamond Needle Corp

B. 駆動軸関係/Crank shaft mechanism/Kurbelwelle/
Mécanisme du vilebrequin/Mecanismo del cigüeñal

REF.NO.	CODE	Q'TY	ヒンメイ	NAME OF PARTS	RMKS
1	146724001	1	クド"ウシ"クA	CRANK SHAFT (A)	※
2	143311001	1	ヘ"アリング"フタ	BEARING CAP	
3	143312000	1	ヘ"アリング"フタパ"ツキン	BEARING CAP PACKING	
4	072600000	1	タマシ"クウク6000	BEARING 6000	
5	062670812	3	ナヘ"コ357-40X8	SCREW 357X8	
7	146473001	1	クド"ウシ"クメタルLクミ	CRANK SHAFT BUSHING (LEFT) ASSEMBLY	
8	143179000	1	クド"ウシ"クメタルMクミ	CRANK SHAFT BUSHING (MIDDLE) ASSEMBLY	
9	110668001	1	シメネジ"4.76	SCREW 4.76	
10	140084000	1	オイルキリ	OIL REJECTOR	
11	110673000	1	ヘ"アリング"フタ	BEARING COVER	
12	107244001	4	サラネジ"3.18	SCREW 3.18	
13	110670000	1	ヘ"アリング"ケース	BEARING CASE	
14	062681012	4	ナヘ"コ437-40X10	SCREW 437X10	
15	072600100	2	タマシ"クウク6001	BEARING 6001	
16	110672000	1	ヘ"アリング"カラー	BEARING COLLAR	
17	147848101	1	プーリー	PULLEY	
18	013761410	2	トメネジ"5.95クホ"ミ	SCREW 5.95	
19	140180001	1	プーリオサエネジ"	CAP SCREW	
20	142274001	1	メクラセン	OIL CAP	
※クドウジクAクミ (B-1, D-1, Q-1, R-1) 146915-001				※ Crank Shaft (A) Assembly (B-1, D-1, Q-1, R-1) 146915-001	

C. 針冷却装置/Needle cooler/Nadelkühlungsvorrichtung/
Mécanisme du refroidisseur d'aiguille/Mecanismo del enfriador de aguja

REF.NO.	CODE	Q'TY	ヒンメイ	NAME OF PARTS	RMKS
1	146511100	1	エキレイタンククミ	SILICONE OIL TANK ASSEMBLY	
1-1	154928000	1	ハリイトレイキヤクタンクフタ	NEEDLE THREAD COOLER TANK COVER	
2	062681012	1	ナヘ"コ437-40X10	SCREW 437X10	
3	112348001	2	パ"ツキン	PACKING	
4	112359001	1	ハイユハイフ"ツキ"テネジ"	SCREW	
5	146512101	1	ビ"ニルチューブ"クミ	VINYL TUBE ASSEMBLY	
6	112348001	4	パ"ツキン	PACKING	
7	112359001	2	ハイユハイフ"ツキ"テネジ"	SCREW	
8	146515000	1	ハイユハイフ"ツキ"テ	OIL FEEDING PIPE CONNECTOR	
9	112348001	2	パ"ツキン	PACKING	
10	112359001	1	ハイユハイフ"ツキ"テネジ"	SCREW	
11	146516000	2	パイフ"シ"ヨイント	PIPE JOINT	
12	146738000	1	フェルトササイクミ	FELT HOLDER ASSEMBLY	
12-1	146739000	1	フェルトササイ	FELT HOLDER	
12-2	144116000	1	フェルト	FELT	
12-3	146740000	1	フェルトS	FELT (SMALL)	
12-4	S02874001	1	ムシピン	PIN	
13	100257010	2	シメネジ"3.57	SCREW 3.57	
15	100645003	1	ワ"ガ"ネ	WASHER	

D. 針棒關係 / Needle bar mechanism / Nadelstangenvorrichtung /
 Mécanisme de la barre à aiguille / Mecanismo del barra de aguja

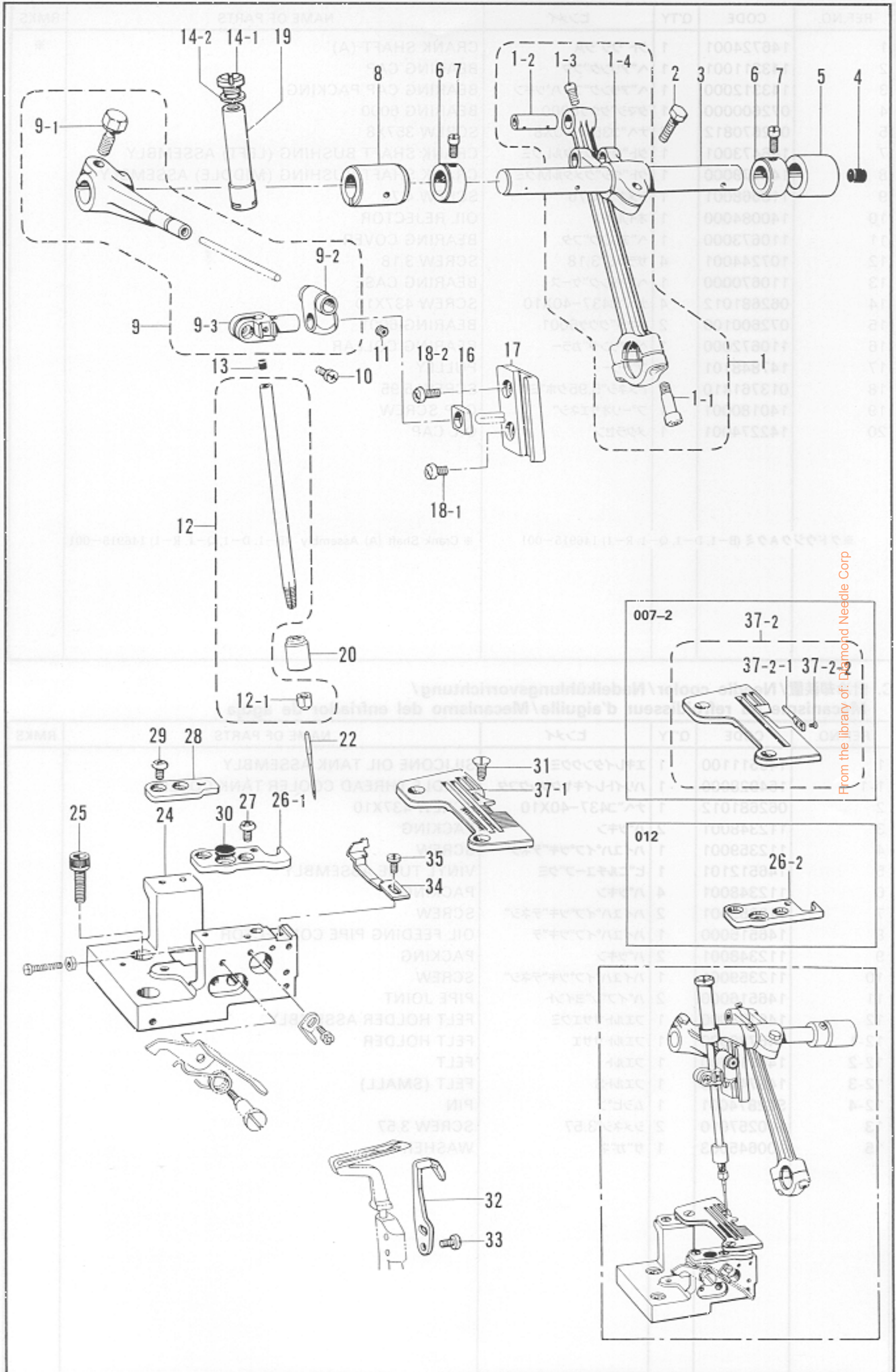

From the library of: Diamond Needle Corp

D. 針棒関係/Needle bar mechanism/Nadelstangenvorrichtung/
Mécanisme de la barre à aiguille/Mecanismo del barra de aguja

REF.NO.	CODE	Q'TY	ヒンメイ	NAME OF PARTS	RMKS
1	146476101	1	ハリホ"ウクランクロツト"クミ	NEEDLE ARM DRIVING CRANK ROD ASSEMBLY	*
1-1	148425001	2	アナホ"ルト4.37X14	BOLT 4.37X14	
1-2	140088001	1	クランクロツト"ピン	PIN	
1-3	100366001	1	マルヒラトメネジ"4.37	SCREW 4.37	
1-4	146478001	1	ハリホ"ウクランクジ"クウテ"	NEEDLE ARM DRIVING LEVER	
2	017771612	1	ホ"ルト6.35X16	BOLT 6.35X16	
3	146479001	1	ハリホ"ウクランクジ"ク	NEEDLE BAR CRANK SHAFT	
4	140327001	1	ゴムセン	OIL CAP	
5	140091000	1	クランクジ"クメタルR	NEEDLE SHAFT BUSHING (RIGHT)	
6	140092001	2	セツトカラー	SET COLLAR	
7	100366001	4	マルヒラトメネジ"4.37	SCREW 4.37	
8	140093000	1	クランクジ"クメタルL	NEEDLE SHAFT BUSHING (LEFT)	
9	146480001	1	ハリホ"ウタ"キクミ	NEEDLE BAR CLAMP ASSEMBLY	
9-1	149170001	1	ホ"ルト6.35X16	BOLT 6.35X16	
9-2	140096001	1	ハリホ"ウツキ"テ	NEEDLE BAR CONNECTOR	
9-3	146482001	1	ハリホ"ウタ"キ	NEEDLE BAR CLAMP	
10	062670812	1	ナヘ"コ357-40X8	SCREW 357X8	
11	146427001	1	アナトメネジ"3.18クホ"ミ	SCREW 3.18	
12	147629001	1	ハリホ"ウクミ	NEEDLE BAR ASSEMBLY	
12-1	147631001	1	ハリト"メナツト	NEEDLE CLAMP NUT	
13	118832000	1	ハリホ"ウセン	NEEDLE BAR CAP	
14	S01652001	1	シメネジ"クミ	SCREW ASSEMBLY	
14-1	S00049001	1	シメネジ"8.73	SCREW 8.73	
14-2	S01654000	1	パツキン	PACKING	
16	159638001	1	ハリホ"ウアンナイカクコマ	NEEDLE BAR GUIDE SLIDE BLOCK	
17	105079001	1	ハリホ"ウアンナイ	NEEDLE BAR GUIDE	
18-1	062680712	1	ナヘ"コ437-40X7	SCREW 437X7	
18-2	S10774001	1	ナヘ"コ437-40X7	SCREW 437X7	
19	S01417001	1	ハリホ"ウメタルU	NEEDLE BAR BUSHING (UPPER)	
20	159636000	1	ハリホ"ウメタルD	NEEDLE BAR BUSHING (LOWER)	
22	*	1	ミシンハリDCX1	NEEDLE DCX1	
24	146725002	1	ハリイタササエ"イ	NEEDLE PLATE SUPPORT BRACKET	
25	018061622	2	アナホ"ルト6X16	BOLT 6X16	
26-1	146494001	1	ハリイタササエ"イ"フ	NEEDLE PLATE SUPPORTER (FRONT)	
26-2	S09240001	1	ハリイタササエ"イ"フ <ハ"ックタックヨウ>	NEEDLE PLATE SUPPORTER (FRONT) <FOR BACK TACKING>	
27	060680512	2	ハ"イント"437-40X5	SCREW 437X5	
28	146495001	1	ハリイタササエ"イ"フ	NEEDLE PLATE SUPPORTER (REAR)	
29	060680512	2	ハ"イント"437-40X5	SCREW 437X5	
30	111486001	1	クロスプレートクッション	CLOTH PLATE CUSHION	
31	100032003	2	サラネジ"4.37	SCREW 4.37	
32	144127001	1	イト"ウハリウケA	MOVABLE NEEDLE GUARD (A)	
33	062670812	2	ナヘ"コ357-40X8	SCREW 357X8	
34	146726001	1	ハリウケF	NEEDLE GUARD (F)	
35	062670612	1	ナヘ"コ357-40X6	SCREW 357X6	
37-1	*	1	ハリイタ	NEEDLE PLATE	
37-2	153544001	1	ハリイタクミ	NEEDLE PLATE ASSEMBLY	
37-2-1	148354101	1	タンク"プレート	TONGUE PLATE	
37-2-2	148355001	2	サラネジ"1.59	SCREW 1.59	
※クドウジクAクミ (B-1, D-1, Q-1, R-1) 146915-001				※ Crank Shaft (A) Assembly (B-1, D-1, Q-1, R-1) 146915-001	

From the library of: Diamond Needle Corp

E. 押工関係/Presser foot mechanism/Stoffdrückerfuß/
 Mécanisme du pied presseur/Mecanismo del prensa telas

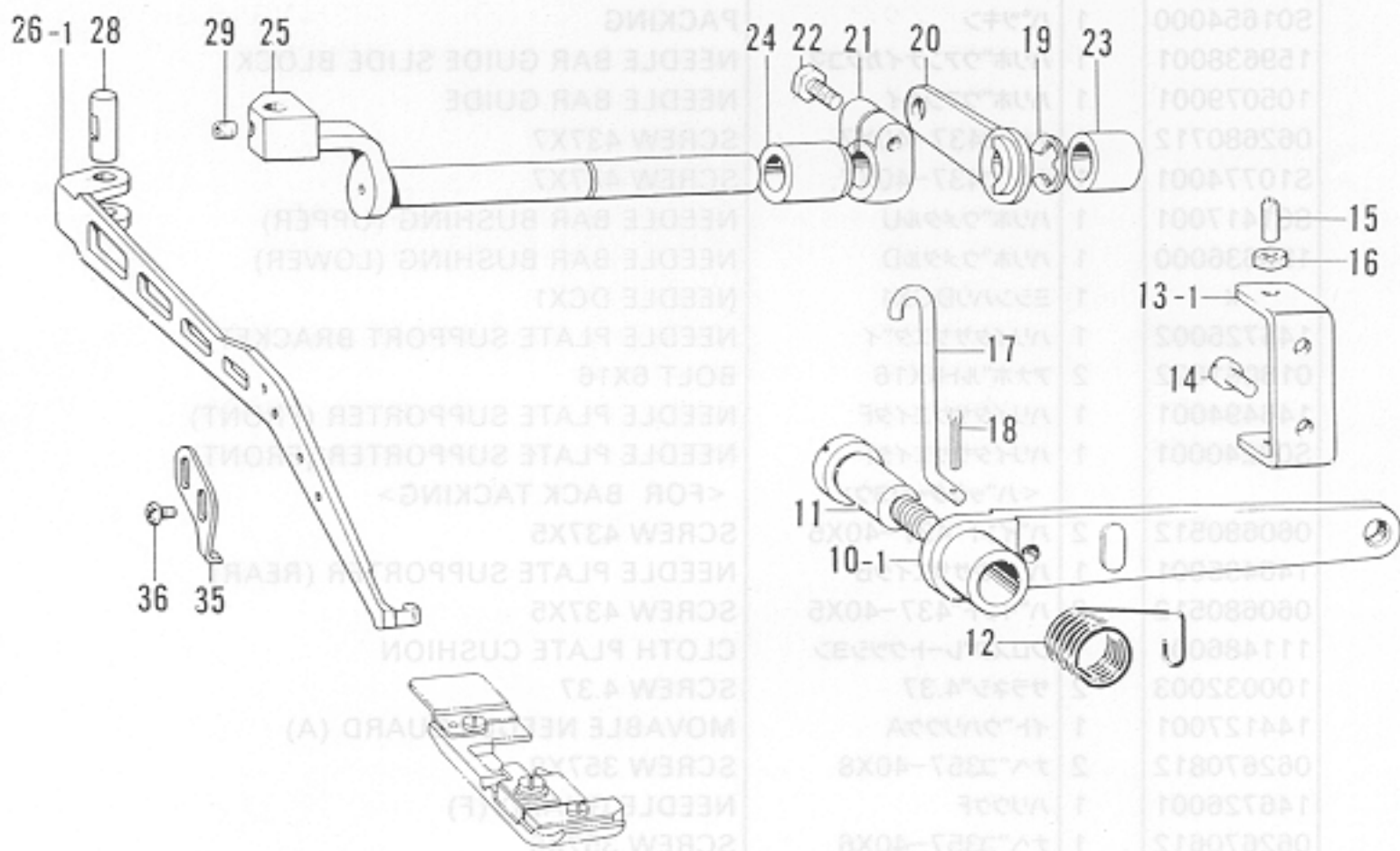
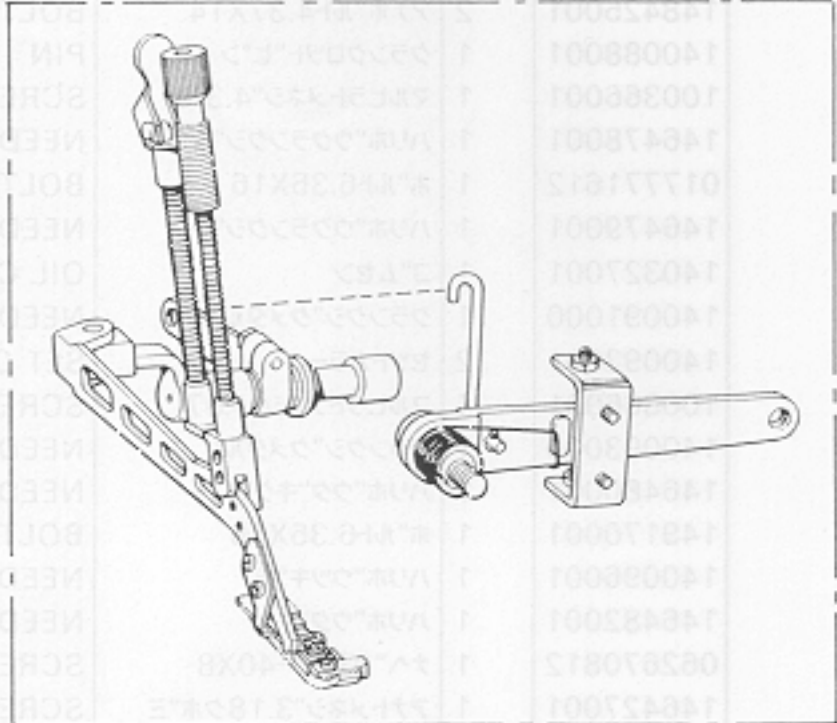
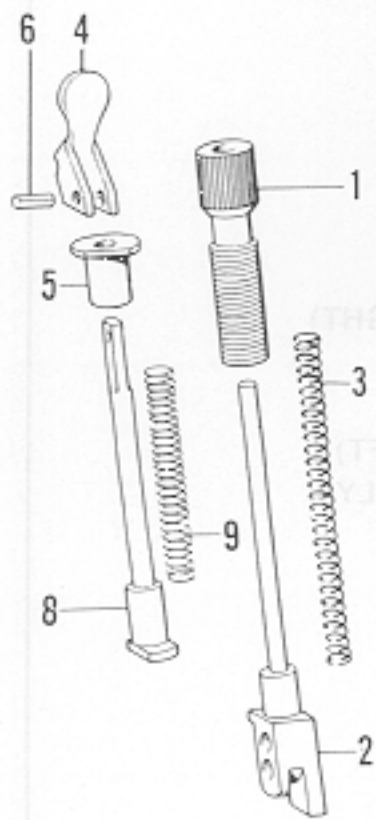

From the library of: Diamond Needle Corp

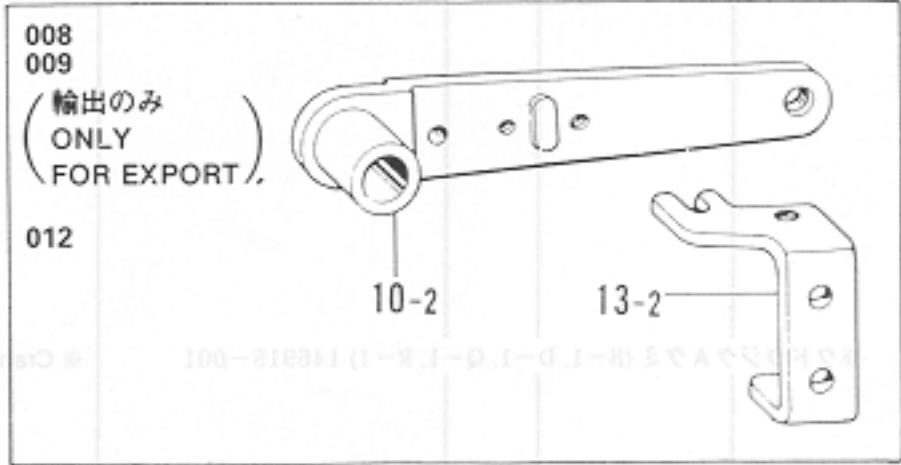
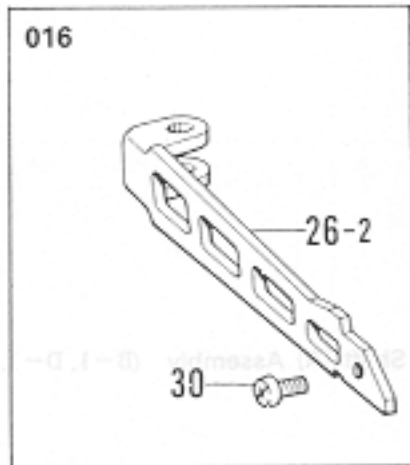
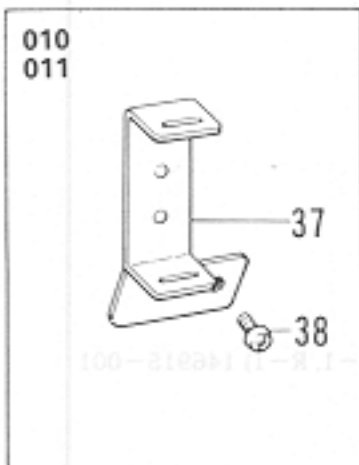

E. 押工関係/Presser foot mechanism/Stoffdrückerfuß/
 Mécanisme du pied presseur/Mecanismo del prensa telas

REF.NO.	CODE	Q'TY	ヒンメイ	NAME OF PARTS	RMKS
1	144079001	1	オサエチヨウセツネシ	PRESSER ADJUSTING SCREW	
2	146521001	1	オサエホ"ウ	PRESSER BAR	
3	144081001	1	オサエハ"ネ	PRESSER SPRING	
4	S06561001	1	オサエテアケ"	PRESSER BAR LIFTER	
5	144083001	1	オサエテアケ"サ"	PRESSER BAR LIFTER BASE	
6	047300842	1	スプリング"ヒンAW3	SPRING PIN AW3	
8	144085001	1	オサエホ"ウアケ"	PRESSER BAR LIFTER SHAFT	
9	144086001	1	オサエホ"ウアケ"ハ"ネ	PRESSER BAR LIFTER SPRING	
10-1	143323103	1	オサエアジアケ"レハ"ー	PRESSER FOOT LIFTER LEVER	
10-2	148369101	1	オサエアジアケ"レハ"ー	PRESSER FOOT LIFTER LEVER	
11	148372001	1	タ"ンネシ"7.94	STUD SCREW 7.94	
12	143325001	1	オサエアジアケ"レハ"ーハ"ネ	SPRING	
13-1	146522001	1	レハ"ーチヨウセツイタ	LEVER ADJUSTER PLATE	
13-2	147454001	1	レハ"ーチヨウセツイタ	LEVER ADJUSTER PLATE	
14	062680712	2	ナヘ"コ437-40X7	SCREW 437X7	
15	153483001	2	トメネシ"4.76	SCREW 4.76	
16	110161006	2	ナツト4.76	NUT 4.76	
17	146523001	1	オサエアケ"リンク	PRESSER FOOT LIFTER LINK	
18	110793001	1	フリヒン	PIN	
19	048080342	1	トメフE8	STOP RING E8	
20	146524001	1	オサエアジアケ"Mレハ"ー	PRESSER FOOT LIFTER INSIDE LEVER	
21	140261001	1	セツトカラー	SET COLLAR	
22	017771612	1	ボ"ルト6.35X16	BOLT 6.35X16	
23	140262000	1	オサエウデ"シクメタルR	PRESSER ARM SHAFT BUSHING (RIGHT)	
24	140263000	1	オサエウデ"シクメタルL	PRESSER ARM SHAFT BUSHING (LEFT)	
25	146525001	1	オサエウデ"シク	PRESSER ARM SHAFT	
26-1	146789001	1	オサエウデ"	MAIN PRESSER ARM	
26-2	146526001	1	シユオサエウデ"<ウツマキヨウ>	MAIN PRESSER ARM <FOR OVER WINDING>	
28	146527001	1	オサエウデ"ヒン	PIN FOR PRESSER ARM SHAFT	
29	014680422	1	アナトメネシ"4.37クホ"ミ	SCREW 4.37	
30	062680712	1	ナヘ"コ437-40X7 <ウツマキヨウ>	SCREW 437X7 <FOR OVER WINDING>	
35	140504001	1	オサエストツハ"	PRESSER FOOT STOPPER	
36	060660512	2	ハ"イント"318-40X5	SCREW 318X5	
37	146883001	1	テープ"アンナイ <テープ"ツケヨウ>	TAPE GUIDE <FOR TAPING>	
38	062660412	2	ナヘ"コ318-40X4 <テープ"ツケヨウ>	SCREW 318X4 <FOR TAPING>	

From the library of: Diamond Needle Corp

E. 押工関係/Presser foot mechanism/Stoffdrückerfuß/
 Mécanisme du pied presseur/Mecanismo del prensa telas

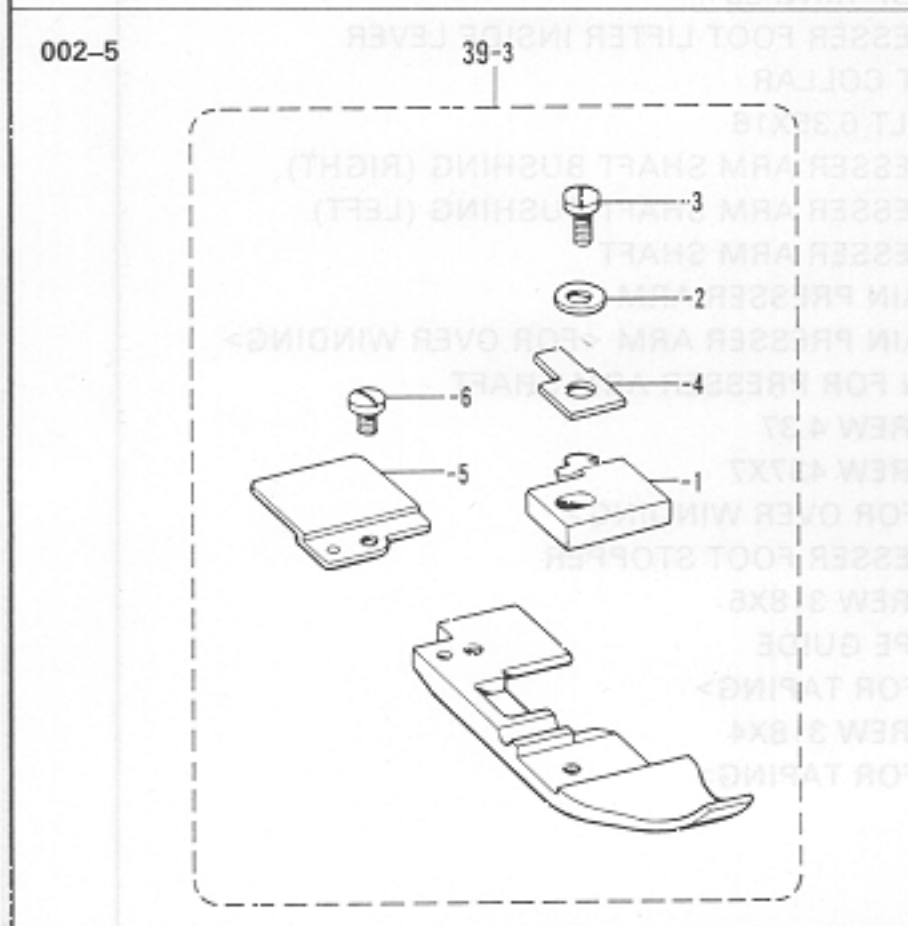
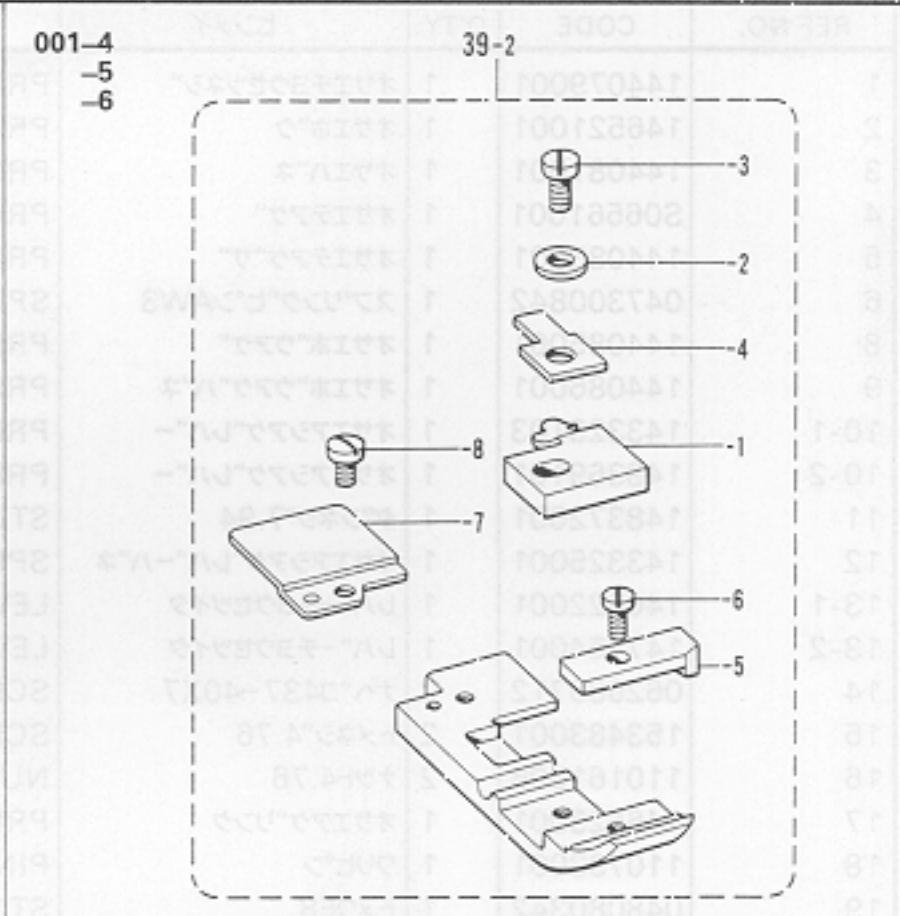
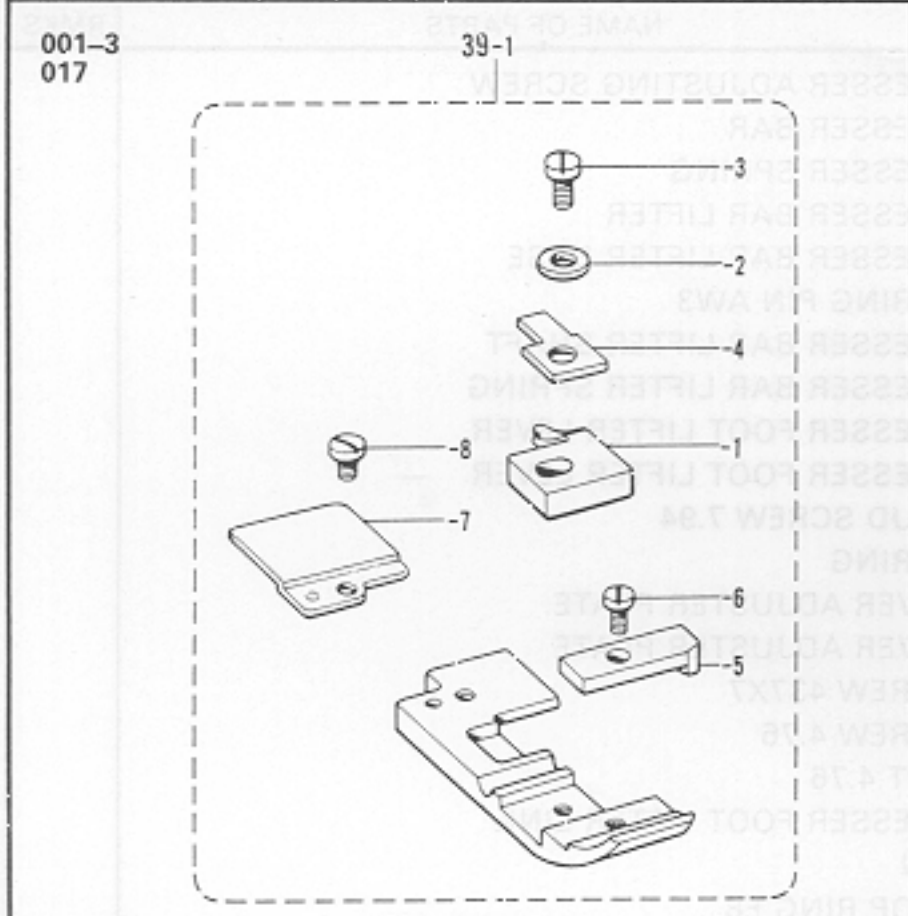

From the library of: Diamond Needle Corp

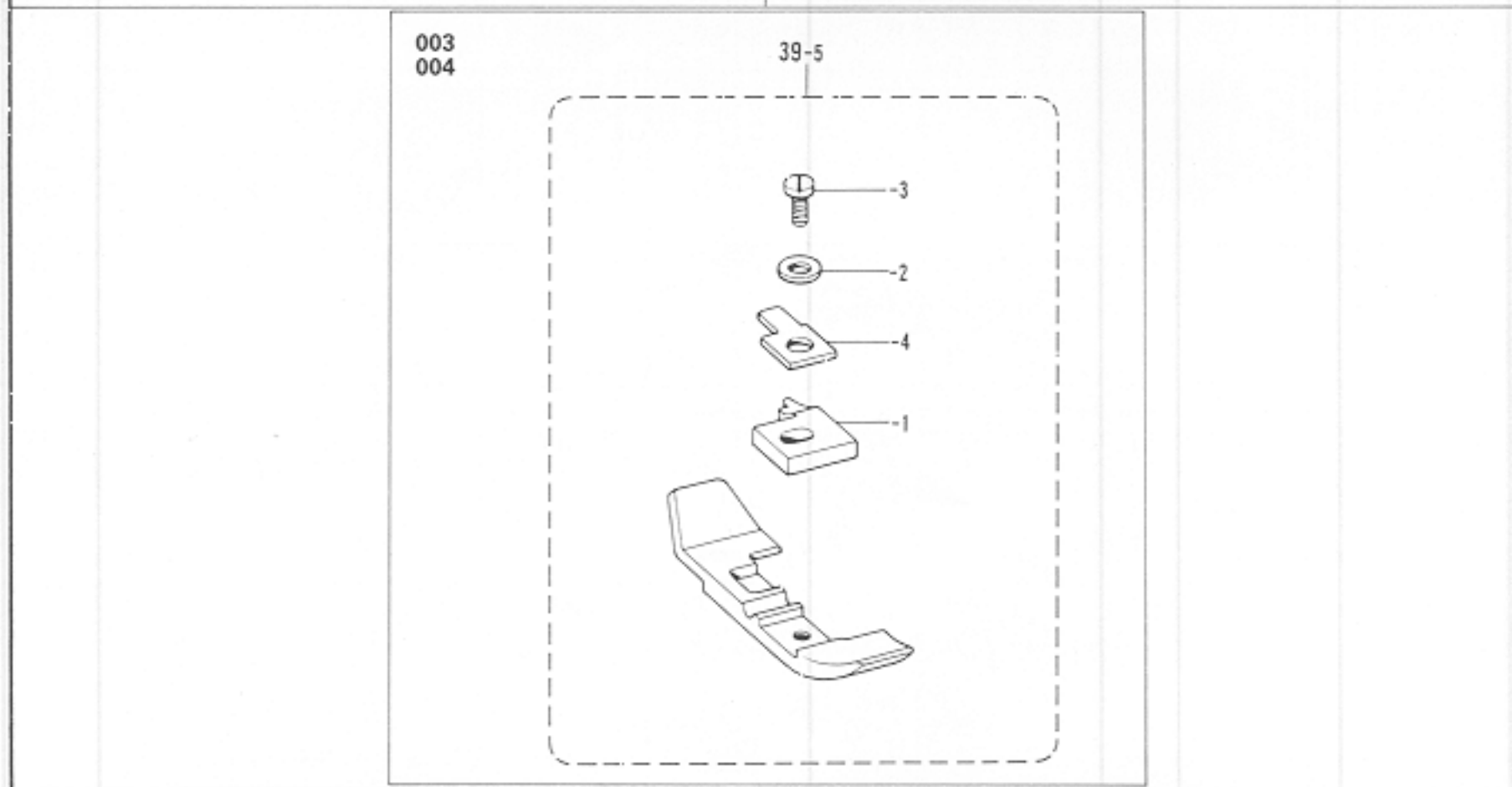

E. 押工関係/Presser foot mechanism/Stoffdrückerfuß/
 Mécanisme du pied presseur/Mecanismo del prensa telas

REF.NO.	CODE	Q'TY	ヒンメイ	NAME OF PARTS	RMKS
39-1	156558101	1	オサイクミ<017>	PRESSER FOOT ASSEMBLY <001-3.017>	
39-1-1	146886002	1	ツメ	STITCH TONGUE	
39-1-2	025030132	1	ヒラサ"カ"ネシヨウ3	WASHER 3	
39-1-3	100080004	1	シメネジ"3.18	SCREW 3.18	
39-1-4	146887001	1	オサイササエ	PRESSER FOOT PLATE	
39-1-5	146888002	1	オサイF	PRESSER FOOT (FRONT)	
39-1-6	S01295001	1	シメネジ"2.38X3.5	SCREW 2.38X3.5	
39-1-7	154969002	1	オサイB	PRESSER FOOT (REAR)	
39-1-8	105288001	1	シメネジ"2.38	SCREW 2.38	
39-2	156562101	1	オサイクミ<001-4,-5>	PRESSER FOOT ASSEMBLY <001-4,-5,-6>	
39-2-1	149524002	1	ツメ	STITCH TONGUE	
39-2-2	025030132	1	ヒラサ"カ"ネシヨウ3	WASHER 3	
39-2-3	100080004	1	シメネジ"3.18	SCREW 3.18	
39-2-4	146887001	1	オサイササエ	PRESSER FOOT PLATE	
39-2-5	146888002	1	オサイF	PRESSER FOOT (FRONT)	
39-2-6	S01295001	1	シメネジ"2.38X3.5	SCREW 2.38X3.5	
39-2-7	154969002	1	オサイB	PRESSER FOOT (REAR)	
39-2-8	105288001	1	シメネジ"2.38	SCREW 2.38	
39-3	S03828001	1	オサイクミ <002-5>	PRESSER FOOT ASSEMBLY <002-5>	
39-3-1	S03829001	1	ツメ	STITCH TONGUE	
39-3-2	025030132	1	ヒラサ"カ"ネシヨウ3	WASHER 3	
39-3-3	100080004	1	シメネジ"3.18	SCREW 3.18	
39-3-4	146887001	1	オサイササエ	PRESSER FOOT PLATE	
39-3-5	154969002	1	オサイB	PRESSER FOOT (REAR)	
39-3-6	105288001	1	シメネジ"2.38	SCREW 2.38	
39-4	154974001	1	-----	PRESSER FOOT ASSEMBLY <002-6,-7>	
39-4-1	146900001	1	-----	STITCH TONGUE	
39-4-2	025030132	1	-----	WASHER 3	
39-4-3	100080004	1	-----	SCREW 3.18	
39-4-4	146887001	1	-----	PRESSER FOOT PLATE	
39-4-5	154969002	1	-----	PRESSER FOOT (REAR)	
39-4-6	105288001	1	-----	SCREW 2.38	
39-5	146890201	1	オサイクミ<003>	PRESSER FOOT ASSEMBLY <003.004>	
39-5-1	S11054101	1	ツメ	STITCH TONGUE	
39-5-2	025030132	1	ヒラサ"カ"ネシヨウ3	WASHER 3	
39-5-3	100080004	1	シメネジ"3.18	SCREW 3.18	
39-5-4	146887001	1	オサイササエ	PRESSER FOOT PLATE	

From the library of: Diamond Needle Corp

E. 押工関係/Presser foot mechanism/Stoffdrückerfuß/
 Mécanisme du pied presseur/Mecanismo del prensa telas

005
006

39-6

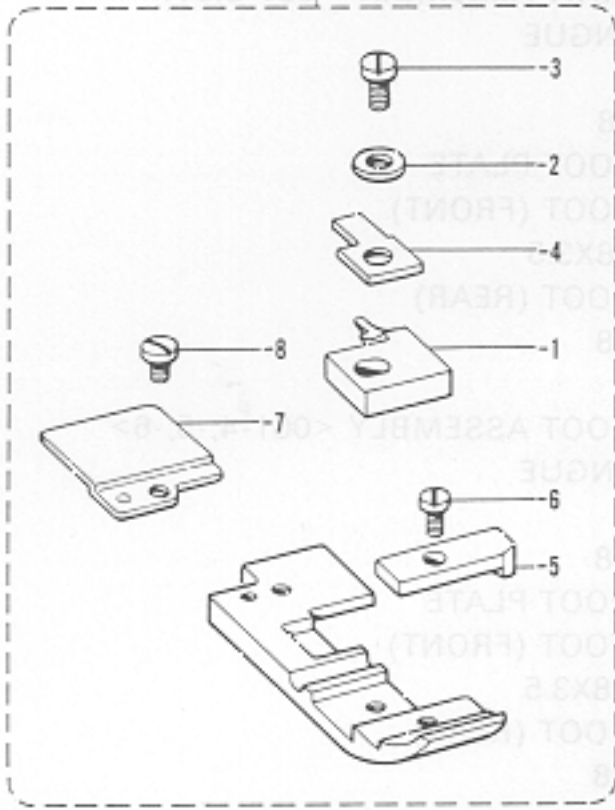

007-2

39-7

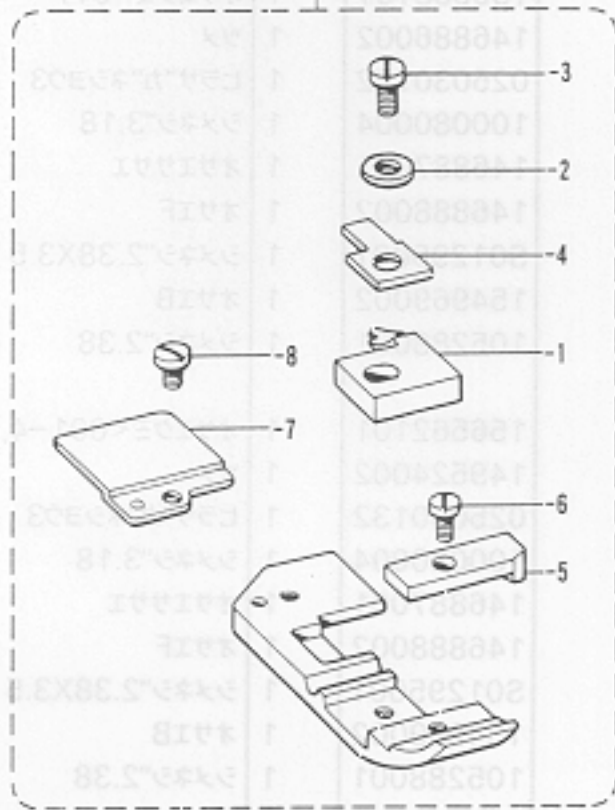

輸出用/ FOR EXPORT
007-4

39-8

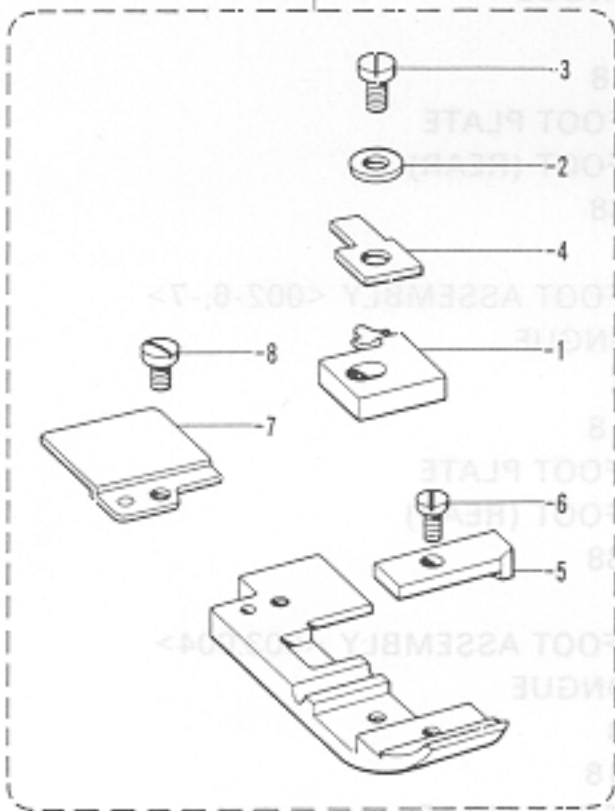

008

39-9

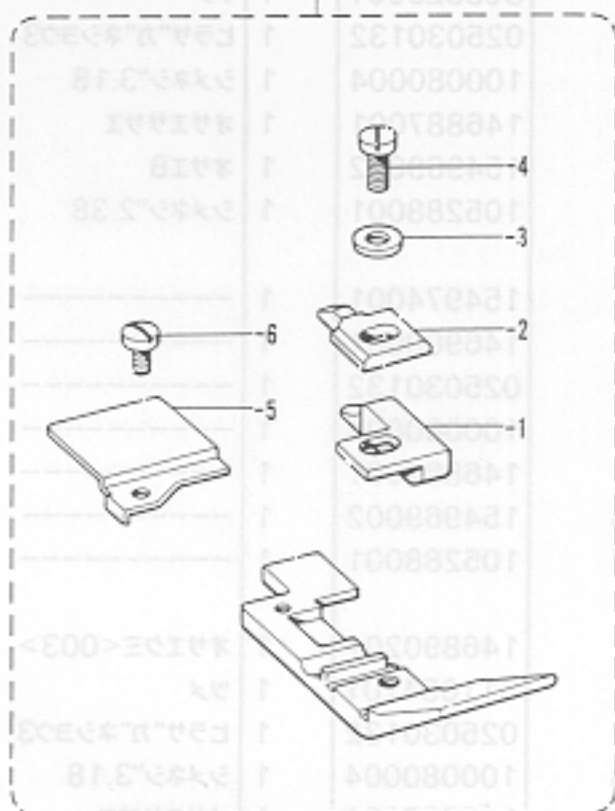

輸出用/ FOR EXPORT
009

39-10

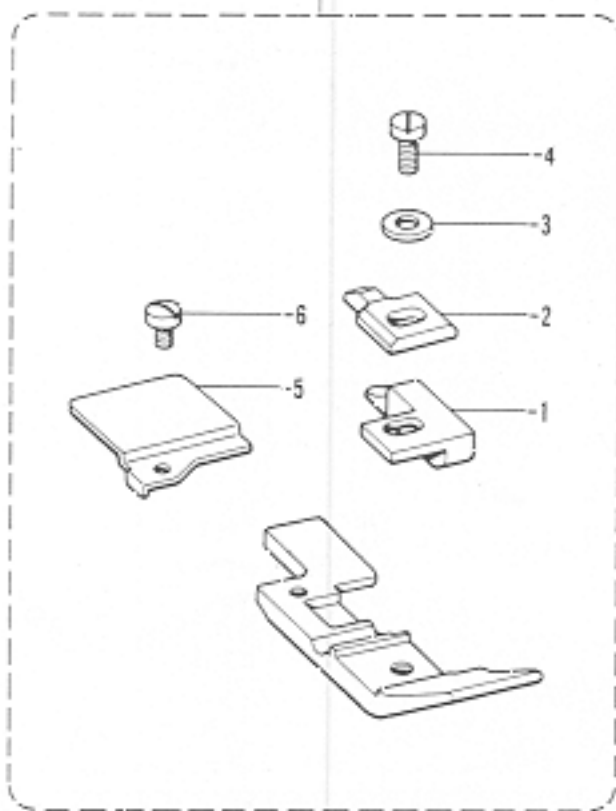

From the library of: Diamond Needle Corp

E. 押工関係/Presser foot mechanism/Stoffdrückerfuß/
 Mécanisme du pied presseur/Mecanismo del prensa telas

REF.NO.	CODE	Q'TY	品名	NAME OF PARTS	RMKS
39-6	154970201	1	オサイクミ<005>	PRESSER FOOT ASSEMBLY <005.006>	
39-6-1	146894001	1	ツメ	STITCH TONGUE	
39-6-2	025030132	1	ヒラサ"カ"ネシヨウ3	WASHER 3	
39-6-3	100080004	1	シメネジ"3.18	SCREW 3.18	
39-6-4	146887001	1	オサイササ	PRESSER FOOT PLATE	
39-6-5	146888002	1	オサイF	PRESSER FOOT (FRONT)	
39-6-6	S01295001	1	シメネジ"2.38X3.5	SCREW 2.38X3.5	
39-6-7	154969002	1	オサイB	PRESSER FOOT (REAR)	
39-6-8	105288001	1	シメネジ"2.38	SCREW 2.38	
39-7	153547101	1	オサイクミ<007-2>	PRESSER FOOT ASSEMBLY <007-2>	
39-7-1	148313001	1	ツメ	STITCH TONGUE	
39-7-2	025030132	1	ヒラサ"カ"ネシヨウ3	WASHER 3	
39-7-3	100080004	1	シメネジ"3.18	SCREW 3.18	
39-7-4	146887001	1	オサイササ	PRESSER FOOT PLATE	
39-7-5	146888002	1	オサイF	PRESSER FOOT (FRONT)	
39-7-6	S01295001	1	シメネジ"2.38X3.5	SCREW 2.38X3.5	
39-7-7	154969002	1	オサイB	PRESSER FOOT (REAR)	
39-7-8	105288001	1	シメネジ"2.38	SCREW 2.38	
39-8	154976101	1	-----	PRESSER FOOT ASSEMBLY <007-4>	
39-8-1	148313001	1	-----	STITCH TONGUE	
39-8-2	025030132	1	-----	WASHER 3	
39-8-3	100080004	1	-----	SCREW 3.18	
39-8-4	146887001	1	-----	PRESSER FOOT PLATE	
39-8-5	146888002	1	-----	PRESSER FOOT (FRONT)	
39-8-6	S01295001	1	-----	SCREW 2.38X3.5	
39-8-7	154969002	1	-----	PRESSER FOOT (REAR)	
39-8-8	105288001	1	-----	SCREW 2.38	
39-9	S07199001	1	オサイクミ <008>	PRESSER FOOT ASSEMBLY <008>	
39-9-1	144813001	1	ツメU	STITCH TONGUE (U)	
39-9-2	144091001	1	オサイササ	PRESSER FOOT PLATE	
39-9-3	025030132	1	ヒラサ"カ"ネシヨウ3	WASHER 3	
39-9-4	100080004	1	シメネジ"3.18	SCREW 3.18	
39-9-5	154972001	1	オサイB	PRESSER FOOT (REAR)	
39-9-6	105288001	1	シメネジ"2.38	SCREW 2.38	
39-10	154975001	1	-----	PRESSER FOOT ASSEMBLY <009>	
39-10-1	144813001	1	-----	STITCH TONGUE (U)	
39-10-2	144091001	1	-----	PRESSER FOOT PLATE	
39-10-3	025030132	1	-----	WASHER 3	
39-10-4	100080004	1	-----	SCREW 3.18	
39-10-5	154972001	1	-----	PRESSER FOOT (REAR)	
39-10-6	105288001	1	-----	SCREW 2.38	

From the library of: Diamond Needle Corp

E. 押工関係 / Presser foot mechanism / Stoffdrückerfuß /
 Mécanisme du pied presseur / Mecanismo del prensa telas

輸出用 / FOR EXPORT
 010-3

010-4
 -5
 011

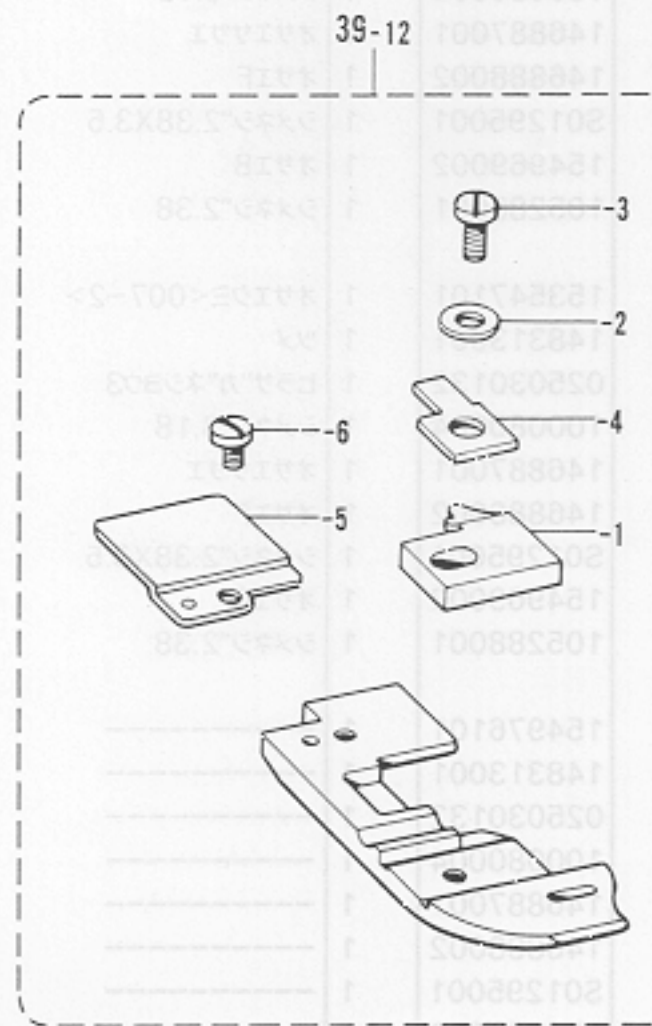
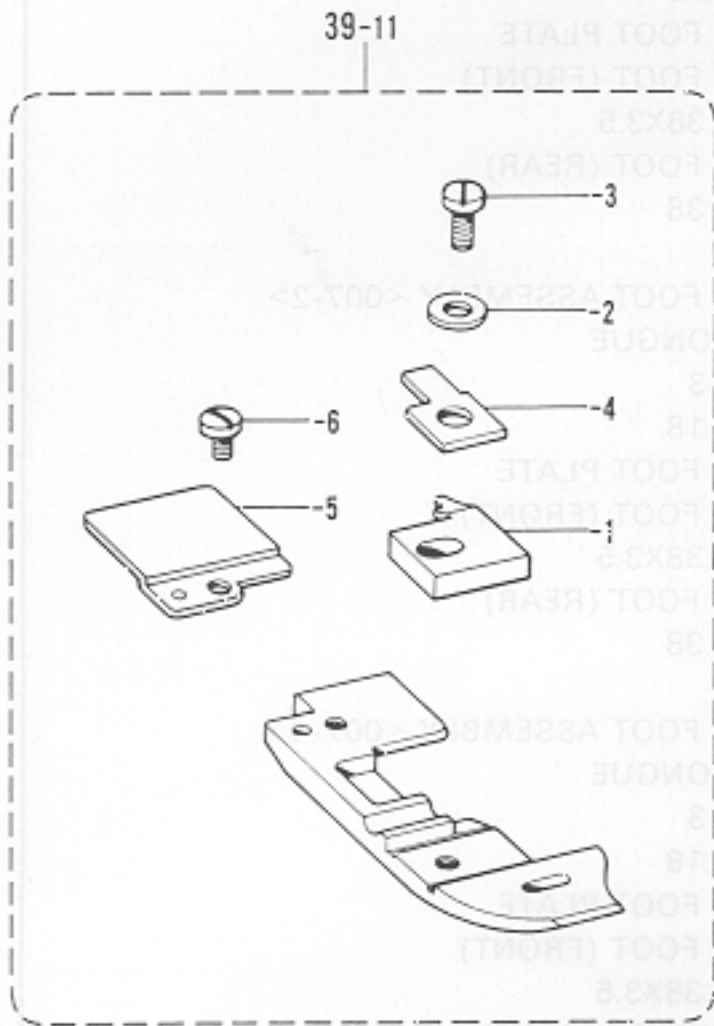

012

016

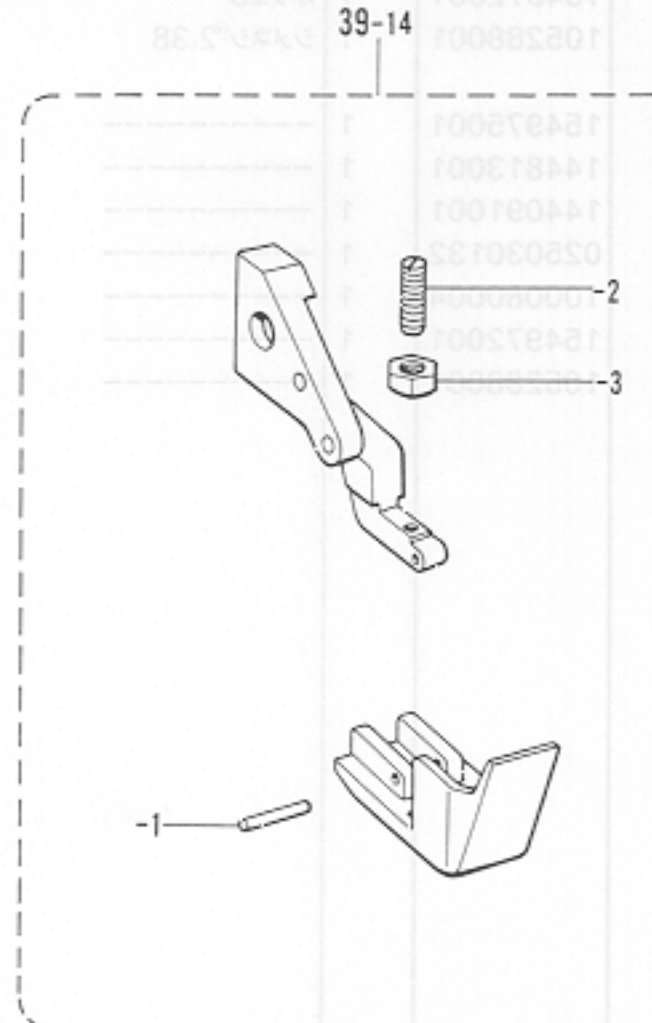
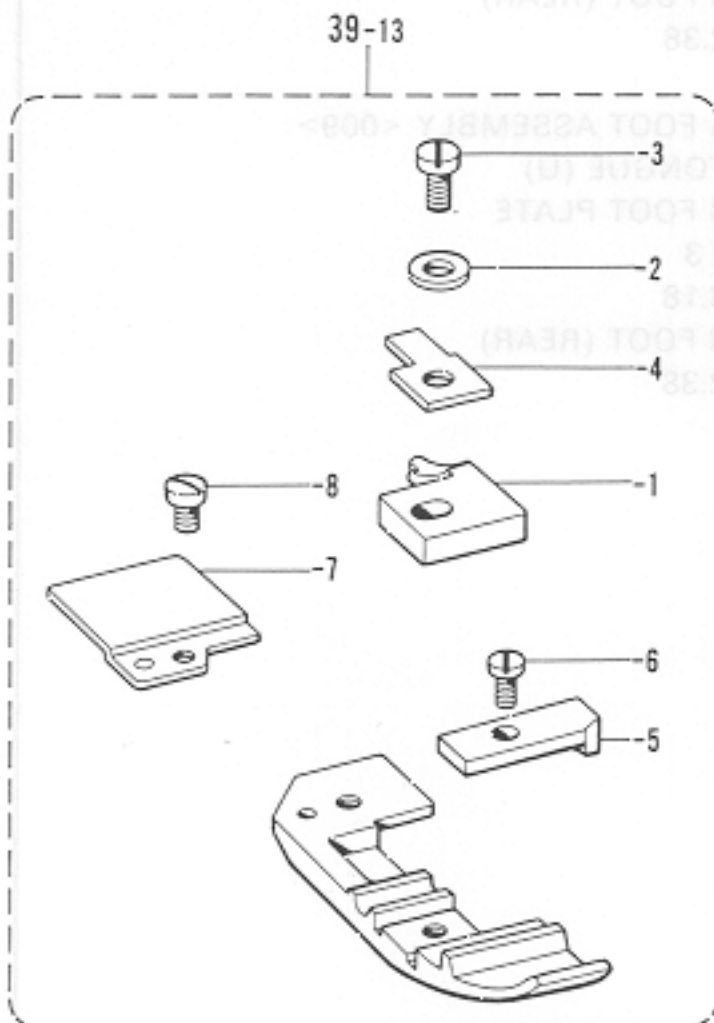

From the library of: Diamond Needle Corp

E. 押工関係/Presser foot mechanism/Stoffdrückerfuß/
 Mécanisme du pied presseur/Mecanismo del prensa telas

REF.NO.	CODE	Q'TY	ヒンメイ	NAME OF PARTS	RMKS
39-11	159367001	1	-----	PRESSER FOOT ASSEMBLY <010-3>	
39-11-1	159369001	1	-----	STITCH TONGUE	
39-11-2	025030132	1	-----	WASHER 3	
39-11-3	100080004	1	-----	SCREW 3.18	
39-11-4	146887001	1	-----	PRESSER FOOT PLATE	
39-11-5	154969002	1	-----	PRESSER FOOT (REAR)	
39-11-6	105288001	1	-----	SCREW 2.38	
39-12	156560001	1	オサイクミ<010-5>	PRESSER FOOT ASSEMBLY <010-4,-5.011>	
39-12-1	146897001	1	ツメ	STITCH TONGUE	
39-12-2	025030132	1	ヒラサ"ガ"ネシヨウ3	WASHER 3	
39-12-3	100080004	1	シメネジ"3.18	SCREW 3.18	
39-12-4	146887001	1	オサイササ	PRESSER FOOT PLATE	
39-12-5	154969002	1	オサイB	PRESSER FOOT (REAR)	
39-12-6	105288001	1	シメネジ"2.38	SCREW 2.38	
39-13	S11115101	1	オサイクミ<012>	PRESSER FOOT ASSEMBLY <012>	
39-13-1	146886002	1	ツメ	STITCH TONGUE	
39-13-2	025030132	1	ヒラサ"ガ"ネシヨウ3	WASHER 3	
39-13-3	100080004	1	シメネジ"3.18	SCREW 3.18	
39-13-4	146887001	1	オサイササ	PRESSER FOOT PLATE	
39-13-5	146888002	1	オサイF	PRESSER FOOT (FRONT)	
39-13-6	S01295001	1	シメネジ"2.38X3.5	SCREW 2.38X3.5	
39-13-7	154969002	1	オサイB	PRESSER FOOT (REAR)	
39-13-8	105288001	1	シメネジ"2.38	SCREW 2.38	
39-14	S06008001	1	オサイクミ<016>	PRESSER FOOT ASSEMBLY <016>	
39-14-1	149183001	1	オサイピン	PRESSER PIN	
39-14-2	103978002	1	トメネジ"3.18	SCREW 3.18	
39-14-3	021660102	1	ナット1シ13.18	NUT 3.18	

From the library of: Diamond Needle Corp

F. 送り関係/Feed mechanism/Transportvorrichtung/
 Mécanisme de l'entraînement/Mecanismo de la alimentación

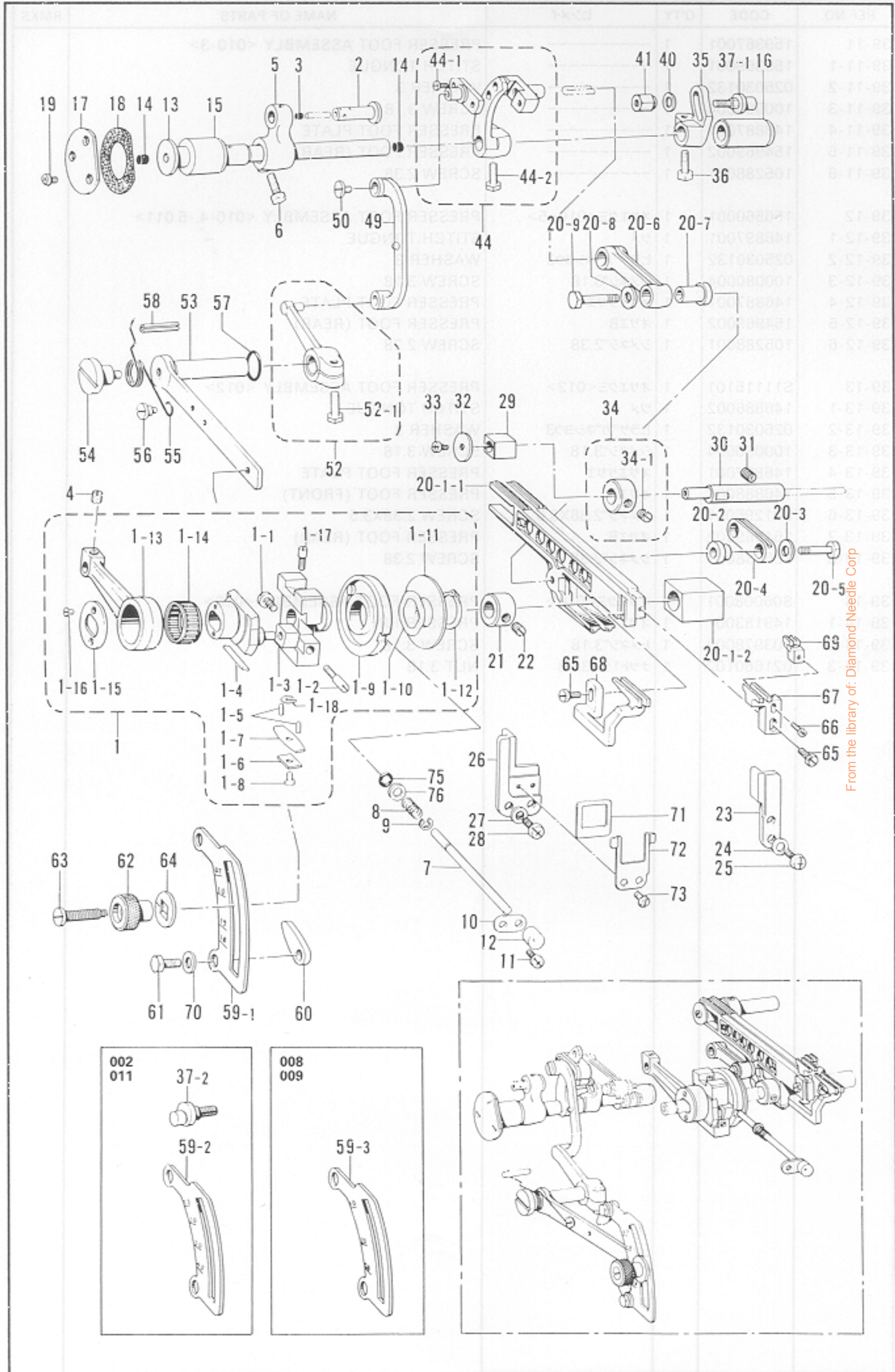

F. 送り関係/Feed mechanism/Transportvorrichtung/
Mécanisme de l'entraînement/Mecanismo de la alimentación

REF.NO.	CODE	Q'TY	ヒンメイ	NAME OF PARTS	RMKS
1	146528001	1	ヘンシンリンクミ	ECCENTRIC WHEEL ASSEMBLY	
1-1	107093002	1	シメネジ"4.37	SCREW 4.37	
1-2	145663001	1	トメネジ"4.37	SCREW 4.37	
1-3	140165001	1	チヨウセツピンカクコマ	SLIDE BLOCK	
1-4	146401001	1	ジ"フ"	GIB	
1-5	146402001	2	ジ"フ"オサエピン	GIB HOLDER PIN	
1-6	146403001	1	ジ"フ"オサエイタハ"ネS	GIB HOLDER PLATE (SMALL)	
1-7	146404001	1	ジ"フ"オサエイタハ"ネL	GIB HOLDER PLATE (LARGE)	
1-8	062660512	1	ナヘ"コネジ"318-40X5	SCREW 318X5	
1-9	144053001	1	ヘンシンチヨウセツカムクミ	ECCENTRIC WHEEL ADJUSTING CAM ASSEMBLY	
1-10	144055001	1	ナミハ"ネ	WAVE SPRING	
1-11	146529001	1	サ"カ"ネ	WASHER	
1-12	048150143	1	トメワシ"クヨウC15	STOP RING C15	
1-13	146530001	1	オクリロツト"	FEED ROD	
1-14	146531001	1	ニート"ルジ"クウク20	NEEDLE ROLLER BEARING 20	
1-15	140176001	1	オクリロツト"オサエイタ	FEED ROD PRESSER PLATE	
1-16	117517003	2	サラネジ"2.38	SCREW 2.38	
1-17	100025002	2	シメネジ"4.76	SCREW 4.76	
1-18	S05721003	1	スペーサ	SPACER	
2	146532001	1	オクリロツト"ピン	FEED ROD PIN	
3	140326001	1	ゴムセン	OIL CAP	
4	100251001	1	トメネジ"6.35	SCREW 6.35	
5	146533001	1	オクリウデ"	FEED ARM	
6	017771612	1	ボ"ルト6.35X16	BOLT 6.35X16	
7	146534001	1	オクリチヨウセツホ"タンジ"ク	FEED ADJUSTING SHAFT	
8	S11072001	1	ホ"タンシ"クハ"ネ	SPRING	
9	048040342	1	トメワE4	STOP RING E4	
10	146536001	1	オクリホ"タンシ"クササE	SUPPORTER FOR FEED ADJUSTING SHAFT	
11	062670612	1	ナヘ"コ357-40X6	SCREW 357X6	
12	146537000	1	キャツプ"	CAP	
13	146538001	1	オクリシ"ク	FEED SHAFT	
14	140327001	2	ゴムセン	OIL CAP	
15	146539000	1	オクリシ"クメタルL	FEED SHAFT BUSHING (LEFT)	
16	146540000	1	オクリシ"クメタルR	FEED SHAFT BUSHING (RIGHT)	
17	140188004	1	オクリシ"クメタルLフタ	COVER FOR FEED SHAFT BUSHING (LEFT)	
18	140187000	1	パツキン	PACKING	
19	062670812	3	ナヘ"コ357-40X8	SCREW 357X8	
20	159475001	1	オクリタ"イカクコマリンククミ	FEED BAR GUIDE BLOCK LINK ASSEMBLY	
20-1	146541001	1	オクリタ"イカクゴ"マクミ	FEED BAR GUIDE BLOCK ASSEMBLY	
20-1-1	147773001	1	オクリタ"イクミ	FEED BAR ASSEMBLY	
20-1-2	146544000	1	ジ"ヨウケ"オクリカクコマ	FEED LIFTING SLIDE BLOCK	
20-2	140207001	1	シユオクリリンクフ"シユ	MAIN FEED LINK BUSHING	
20-3	140208001	1	サ"カ"ネ	WASHER	
20-4	140209001	1	シユオクリリンク	MAIN FEED LINK	
20-5	140210001	1	シユオクリリンクジ"クS	MAIN FEED LINK SHAFT (SMALL)	
20-6	146554001	1	サト"ウオクリリンク	DIFFERENTIAL FEED LINK	
20-7	146555001	1	サト"ウオクリリンクフ"シユ	DIFFERENTIAL FEED LINK BUSHING	
20-8	140208001	1	サ"カ"ネ	WASHER	
20-9	140217001	1	オクリリンクジ"クL	FEED LINK SHAFT (LARGE)	
21	146741000	1	ゼツカラー	SET COLLAR	
22	101706001	1	トメネジ"6.35	SCREW 6.35	
23	148174000	1	オクリタ"イアンナイR	FEED BAR GUIDE (RIGHT)	
24	100645003	2	サ"カ"ネ	WASHER	
25	062681012	2	ナヘ"コ437-40X10	SCREW 437X10	
26	149888000	1	オクリタ"イアンナイL	FEED BAR GUIDE (LEFT)	
27	100645003	2	サ"カ"ネ	WASHER	
28	062681012	2	ナヘ"コ437-40X10	SCREW 437X10	
29	146547000	1	オクリタ"イカクコマ	FEED BAR SLIDE BLOCK	
30	146548101	1	オクリタ"イカクコマシ"ク	FEED BAR GUIDE BLOCK SHAFT	
31	014770622	1	アナトメネジ"6.35クホ"ミ	SCREW 6.35	
32	146549001	1	オクリタ"イカクコマアテイタ	SLIDE PLATE	
33	062680712	1	ナヘ"コ437-40X7	SCREW 437X7	

From the library of: Diamond Needle Corp

F. 送り関係/Feed mechanism/Transportvorrichtung/
 Mécanisme de l'entraînement/Mecanismo de la alimentación

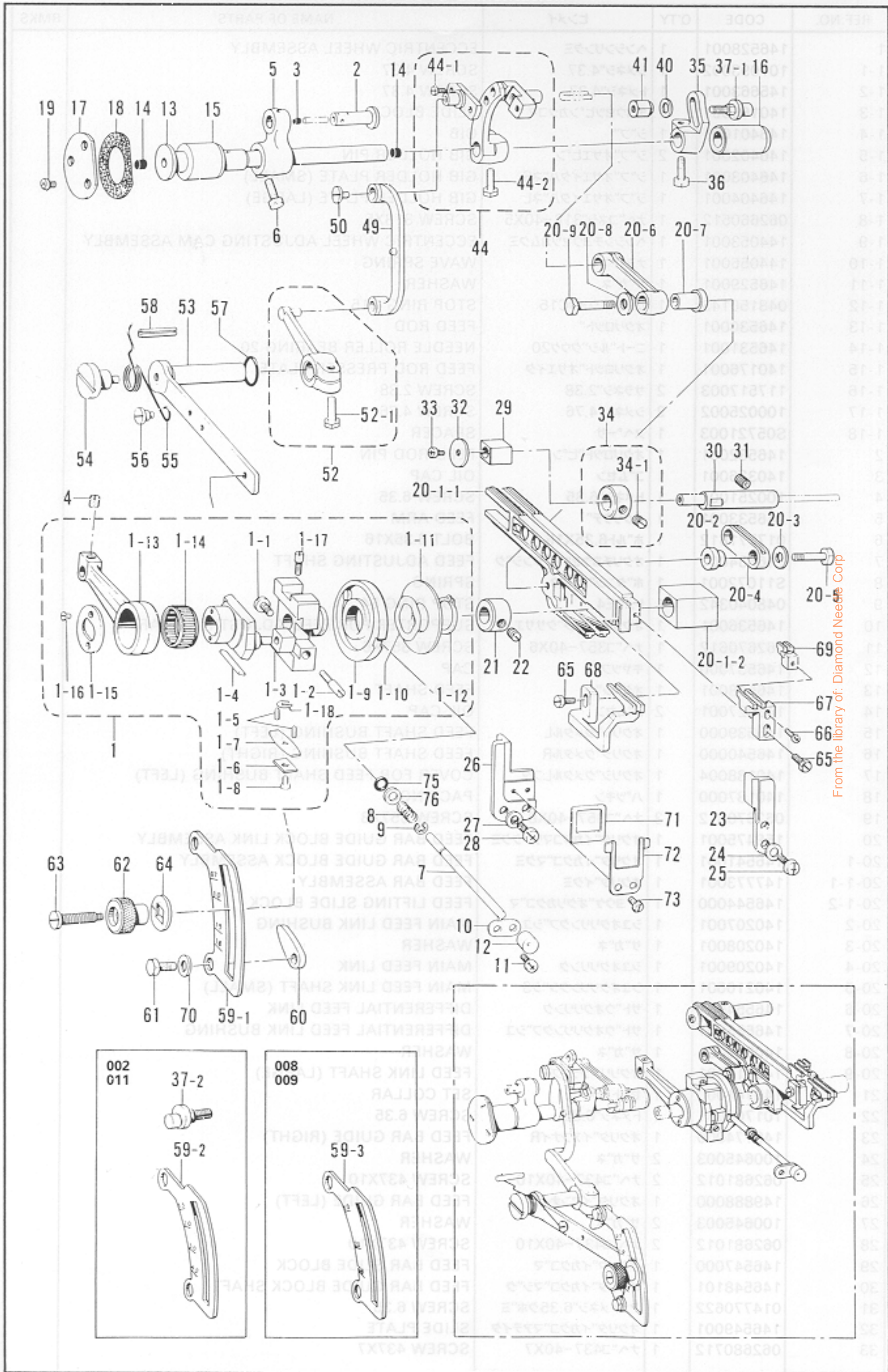

F. 送り関係/Feed mechanism/Transportvorrichtung/
Mécanisme de l'entraînement/Mecanismo de la alimentación

REF.NO.	CODE	Q'TY	ヒンメイ	NAME OF PARTS	RMKS
34	181969003	1	セツトカラークミ	SET COLLAR ASSEMBLY	
34-1	101706001	2	トメネジ"6.35	SCREW 6.35	
35	140205001	1	シユオクリウテ"	MAIN FEED ARM	
36	017771412	1	ボ"ルト6.35X14	BOLT 6.35X14	
37-1	143564001	1	シユオクリシ"ク	MAIN FEED SHAFT	
37-2	144068001	1	シユオクリシ"ク <ハ"ルキ-ヨウ>	MAIN FEED SHAFT <FOR BULKY>	
40	113431002	1	サ"ガ"ネ	WASHER	
41	143565001	1	ナツト4.76	NUT 4.76	
44	146550001	1	サト"ウオクリウテ"クミ	DIFFERENTIAL FEED ARM ASSEMBLY	
44-1	062660712	2	ナヘ"コ318-40X7	SCREW 318X7	
44-2	017771412	1	ボ"ルト6.35X14	BOLT 6.35X14	
49	146556001	1	サト"ウリンク	DIFFERENTIAL FEED ADJUSTING LINK	
50	148834001	1	シメネジ"3.57	SCREW 3.57	
52	146914001	1	リンクレハ"ーネジ"ツキ	LINK LEVER WITH SCREW	
52-1	017771412	1	ボ"ルト6.35X14	BOLT 6.35X14	
53	146558001	1	サト"ウチヨウセツレハ"ー	DIFFERENTIAL FEED ADJUSTING LEVER	
54	146559001	1	タ"ンネジ"5.56	STUD SCREW 5.56	
55	146560101	1	レハ"ーハ"ネ	SPRING	
56	100294002	1	タ"ンネジ"4.76	STUD SCREW 4.76	
57	109203001	1	Oリンク"	O RING	
58	047502242	1	スフ"リンク"ヒ"ンAW5	SPRING PIN AW5	
59-1	146561001	1	サト"ウリヨウメモリタ <シ"ヌイヨウ>	DIFFERENTIAL STITCH CONTROL PLATE <FOR PLAIN STITCHING>	
59-2	146742001	1	サト"ウリヨウメモリタ <ハ"ルキ-ヨウ>	DIFFERENTIAL STITCH CONTROL PLATE <FOR BULKY>	
59-3	146562001	1	サト"ウリヨウメモリタ <ラフラー-ヨウ>	DIFFERENTIAL STITCH CONTROL PLATE <FOR RUFFLING>	
60	146563001	2	チヨウセツレハ"ーストツハ"	STOPPER FOR DIFFERENTIAL STITCH CONTROL	
61	017771612	2	ボ"ルト6.35X16	BOLT 6.35X16	
62	146564001	1	セツトネジ"ツマミ	SET SCREW KNOB	
63	146565001	1	セツトネジ"	SET SCREW	
64	146566001	1	サ"ガ"ネ	WASHER	
65	117516001	2	ボ"ルト4.37	BOLT 4.37	
66	062630812	1	ナヘ"コ238-56X8	SCREW 238X8	
67	*	1	シユオクリハ"	MAIN FEED DOG	
68	*	1	サト"ウオクリハ"	DIFFERENTIAL FEED DOG	
69	*	1	ホジ"ヨオクリハ"	CHAIN FEED DOG	
70	025770232	2	ヒラサ"ガ"ネチユウ6.35	WASHER 6.35	
71	149886000	1	ホ"ウジ"ン-イタ	FRAGMENT PROTECTOR PLATE	
72	149887001	1	ホ"ウジ"ン-イタササエ	FRAGMENT PROTECTOR PLATE SUPPOTER	
73	S01297001	2	シメネジ"3.57X3.5	SCREW 3.57X3.5	
75	118770001	1	ハ"ツキン	PACKING	
76	113431002	1	サ"ガ"ネ	WASHER	

From the library of: Diamond Needle Corp

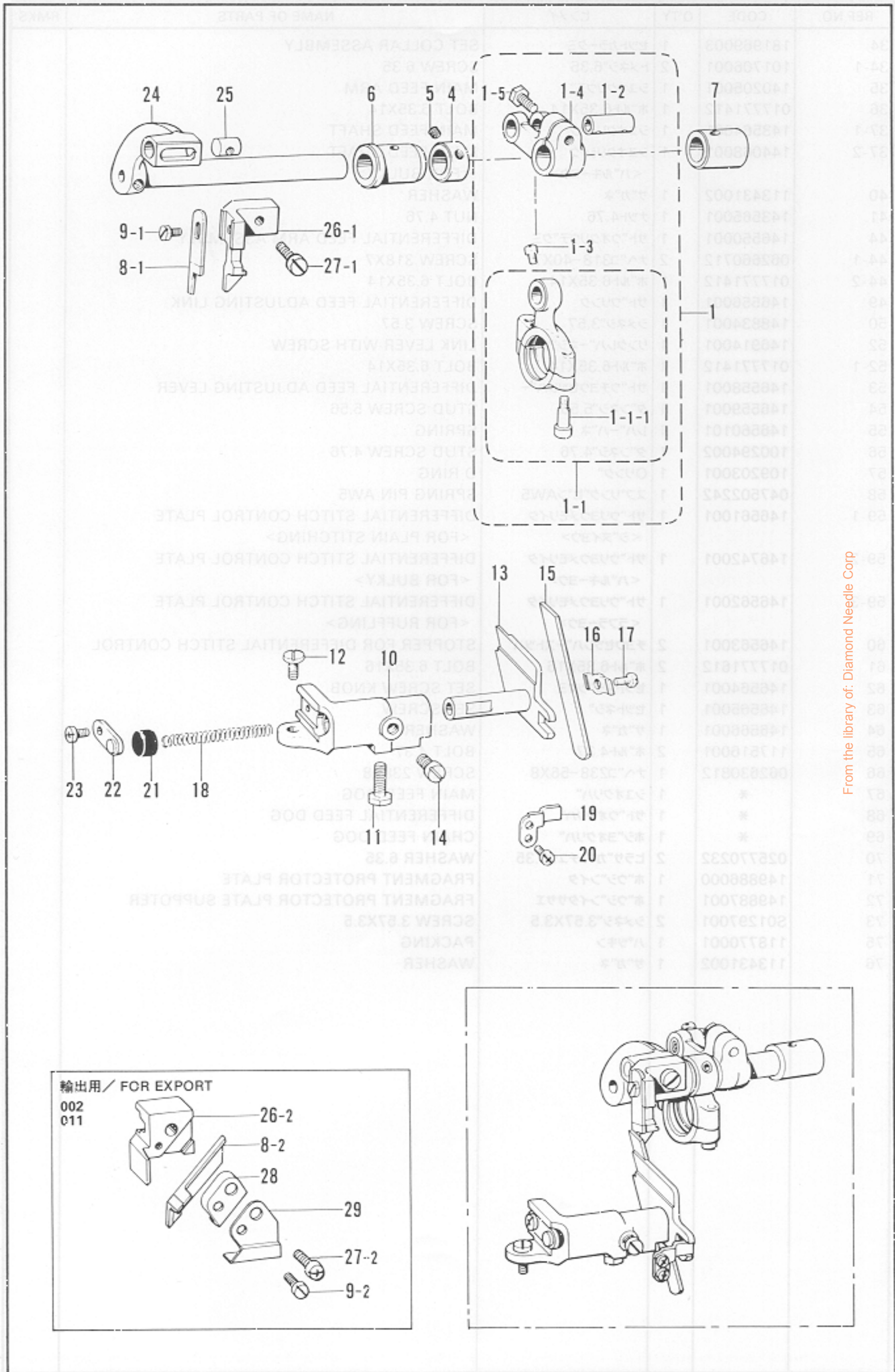

From the library of: Diamond Needle Corp

G. 上メス・下メス関係/Knife mechanism/Messer/Mécanisme du couteau/Mecanismo del cuchilla

REF.NO.	CODE	Q'TY	ヒンメイ	NAME OF PARTS	RMKS
1	148427001	1	ウフメスクランクロット"クミ	UPPER KNIFE DRIVING ROD ASSEMBLY	
1-1	S01223001	1	ウフメスロット"ネジ"ツキ	UPPER KNIFE ROD WITH SCREW	
1-1-1	148425001	2	アナボ"ルト4.37X14	BOLT 4.37X14	
1-2	140232001	1	ウフメスクランクロット"ピン	UPPER CRANK ROD PIN	
1-3	100366001	1	マルヒラトメネジ"4.37	SCREW 4.37	
1-4	140233001	1	ウフメスクランクシ"クウテ"	UPPER KNIFE DRIVING LEVER	
1-5	017771612	1	ボ"ルト6.35X16	BOLT 6.35X16	
4	146581001	1	セツトカラー	SET COLLAR	
5	100260001	2	トメネジ"5.95	SCREW 5.95	
6	140235000	1	ウフメスサト"ウウテ"メタルL	UPPER KNIFE DRIVING ARM BUSHING (LEFT)	
7	144117000	1	ウフメスサト"ウウテ"メタルR	UPPER KNIFE DRIVING ARM BUSHING (RIGHT)	
8-1	*	1	ウフメス	UPPER KNIFE	
9-1	*	1	ボ"ルト3.57	BOLT 3.57	
10	146582001	1	シタメストリツケタ"イササエ	LOWER KNIFE HOLDER SUPPORTER	
11	017771412	1	ボ"ルト6.35X14	BOLT 6.35X14	
12	107407003	1	シメネジ"4.37	SCREW 4.37	
13	146754001	1	シタメストリツケタ"イ	LOWER KNIFE HOLDER	
14	102627001	1	アタマツキトメネジ"6.35	SCREW 6.35	
15	112436001	1	シタメス	LOWER KNIFE	
16	117515001	1	シタメスオサエ	LOWER KNIFE PRESSER PLATE	
17	117516001	1	ボ"ルト4.37	BOLT 4.37	
18	146584001	1	シタメストリツケタ"イハ"ネ	LOWER KNIFE HOLDER SPRING	
19	146585001	1	シタメストリツケタ"イアンナイ	LOWER KNIFE HOLDER GUIDE	
20	062670612	2	ナヘ"コ357-40X6	SCREW 357X6	
21	146586000	1	メクラセン	OIL CAP	
22	140248001	1	トリツケタ"イハ"ネオサエ	LOWER KNIFE HOLDER SPRING STOPPER	
23	062680712	1	ナヘ"コ437-40X7	SCREW 437X7	
24	146580001	1	ウフメスサト"ウウテ"	UPPER KNIFE DRIVING ARM	
25	*	1	ウフメスタ"キナツト	NUT	
26-1	*	1	ウフメスタ"キ	UPPER KNIFE HOLDER	
27-1	*	1	シメネジ"4.37	SCREW 4.37	
<FOR BULKY>					
8-2	148815001	1	-----	UPPER KNIFE	
9-2	113050001	1	-----	SCREW 3.57	
26-2	148341001	1	-----	UPPER KNIFE HOLDER	
27-2	062681612	1	-----	SCREW 437X16	
28	148343101	1	-----	UPPER KNIFE PRESSER	
29	148344001	1	-----	UPPER KNIFE PRESSER PLATE	

From the library of: Diamond Needle Corp

H. ラフラー装置関係 / Ruffling attachment / Kräuseivorrichtung /
 Accessoire pour fronces / Accesorio de fruncido

008, 009

(輸出のみ / ONLY FOR EXPORT)

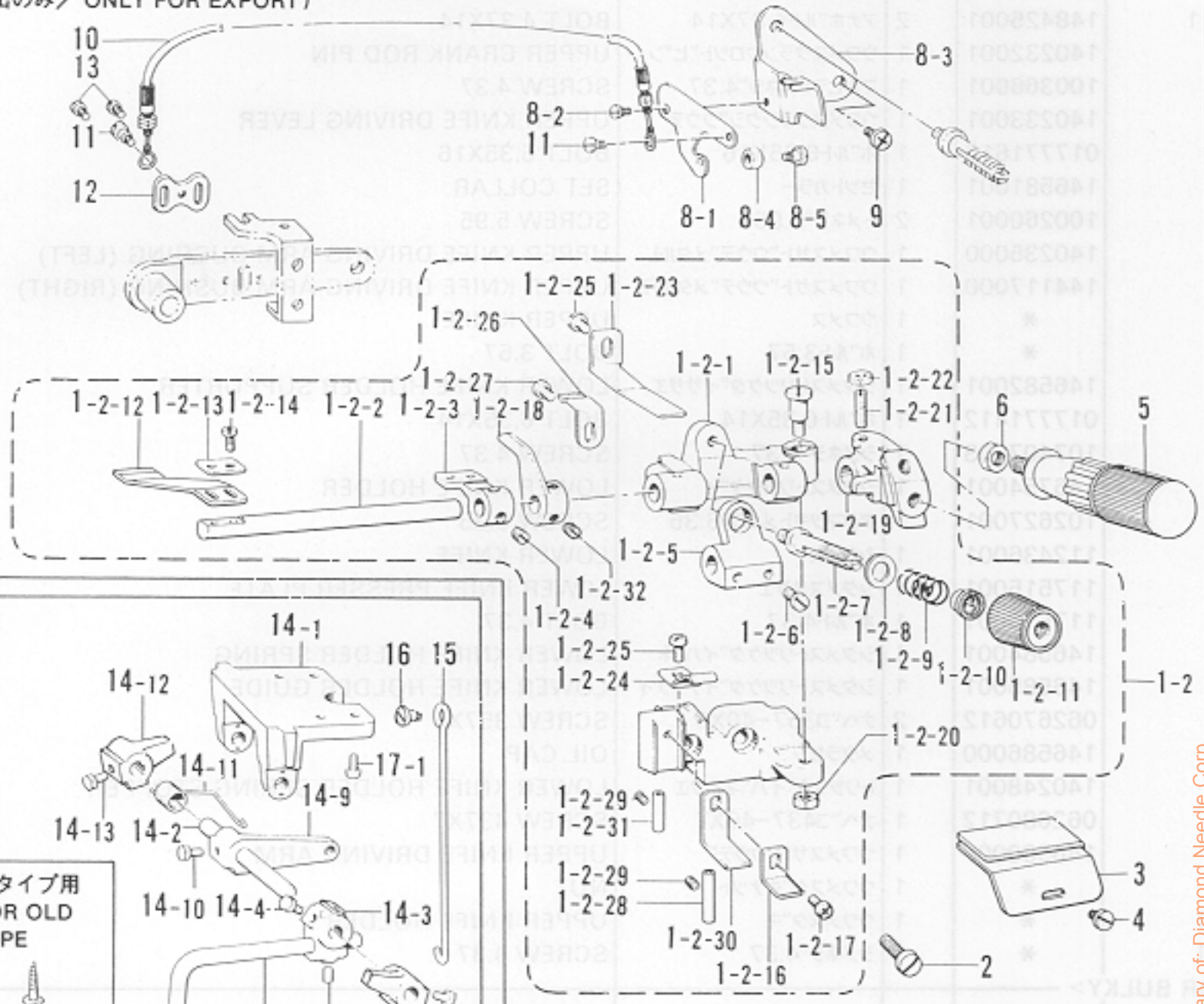

008
009

旧タイプ用
FOR OLD
TYPE

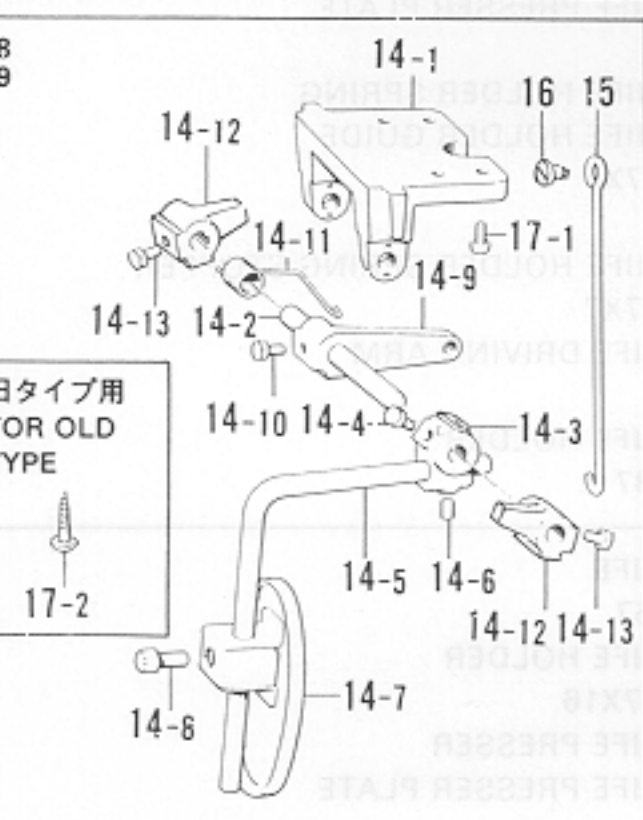

008

(国内のみ / ONLY FOR DOMESTIC)

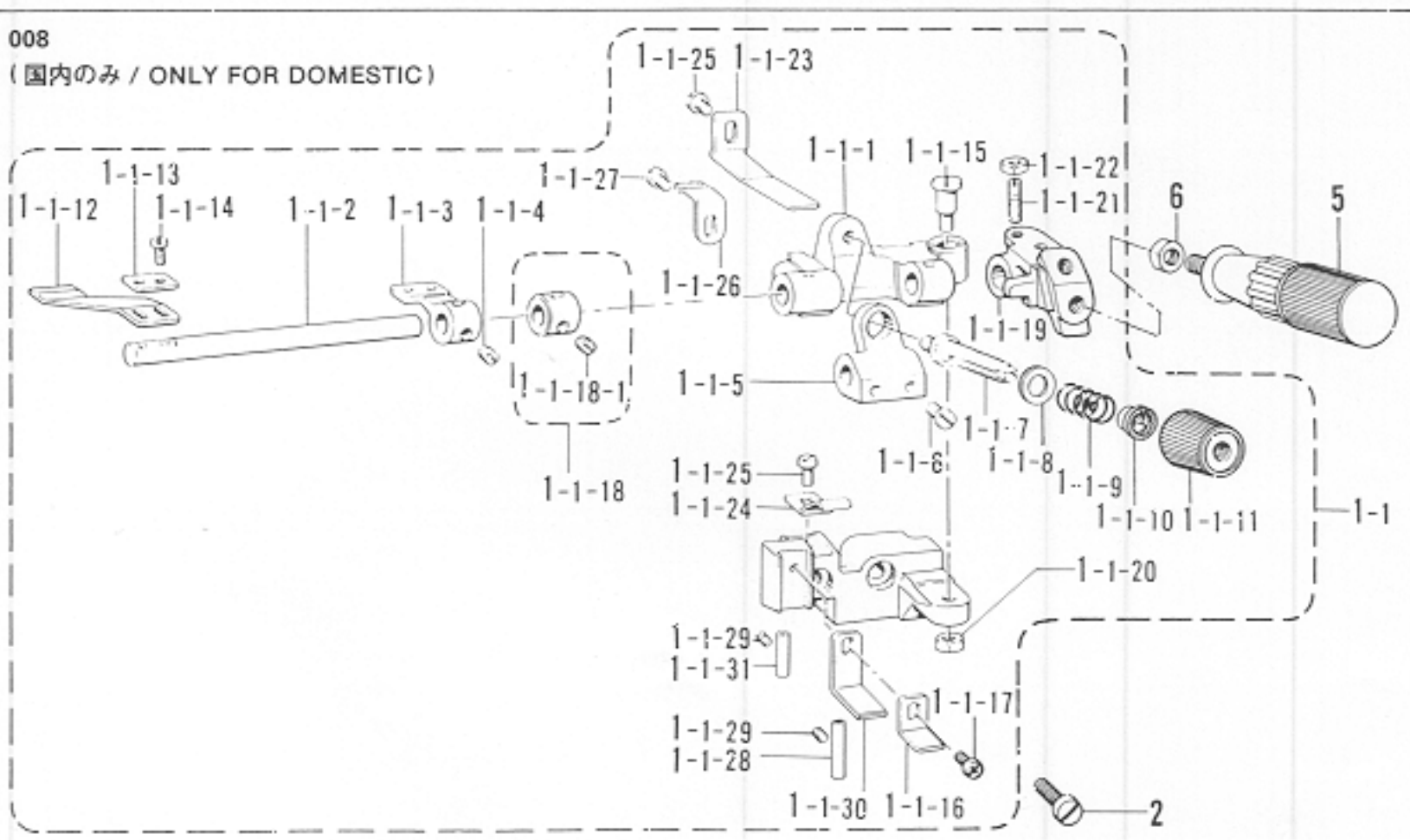

From the library of: Diamond Needle Corp

H. ラフラー装置関係/Ruffling attachment/Kräuselvorrichtung/
Accessoire pour fronces/Accessorio de fruncido

REF.NO.	CODE	Q'TY	ヒンメイ	NAME OF PARTS	RMKS
1-1	146587201	1	ラフラーソウチクミ	-----	
1-1-1	146588001	1	キシ"オサエタイ	-----	
1-1-2	145803001	1	キシ"オサエトリツケシ"ク	-----	
1-1-3	146589001	1	ラツハト"タイ	-----	
1-1-4	101706001	2	トメネシ"6.35	-----	
1-1-5	146590001	1	ハ"ネウケ	-----	
1-1-6	105163001	2	アタマツキトメネシ"5.95	-----	
1-1-7	110820101	1	イトチヨウシホ"ウ	-----	
1-1-8	025770232	1	ヒラサ"ガ"ネチユウ6.35	-----	
1-1-9	144788001	1	キシ"オサエハ"ネ	-----	
1-1-10	144105000	1	チヨウシハ"ネウエサ"ガ"ネ	-----	
1-1-11	149566001	1	イトチヨウシナツト	-----	
1-1-12	144783001	1	キシ"オサエ	-----	
1-1-13	144784001	1	キシ"オサエサ"ガ"ネ	-----	
1-1-14	062660712	2	ナヘ"コ318-40X7	-----	
1-1-15	147933001	1	タ"ンネシ"5.95	-----	
1-1-16	145807001	1	キシ"オサエタイアンナイ	-----	
1-1-17	062680812	1	ナヘ"コ437-40X8	-----	
1-1-18	181995002	1	セツトカラークミ	-----	
1-1-18-1	101706001	2	トメネシ"6.35	-----	
1-1-19	145810001	1	ハント"ルト"リツケイタ	-----	
1-1-20	150553002	1	ナツト5.95	-----	
1-1-21	110230001	1	トメネシ"4.37	-----	
1-1-22	105234003	1	ナツト4.37	-----	
1-1-23	145811001	1	ハント"ル"ト"シイタハ"ネ	-----	
1-1-24	145808001	1	キシ"オサエタイトメハ"ネ	-----	
1-1-25	062680612	2	ナヘ"コ4.37-40X6	-----	
1-1-26	144764001	1	マエフタメイタハ"ネ	-----	
1-1-27	060670512	1	ハ"イント"357-40X5	-----	
1-1-28	146592001	1	イトアンナイハ"イフ"	-----	
1-1-29	013679412	2	トメネシ"3.57クホ"ミ	-----	
1-1-30	154795001	1	キシ"オサエタイアンナイD	-----	
1-1-31	S01614001	1	イトアンナイハ"イフ"	-----	
1-2	S12677001	1	-----	RUFFLER ATTACHMENT ASSEMBLY	
1-2-1	146588001	1	-----	BRACKET FOR RUFFLING BLADE	
1-2-2	145803001	1	-----	RUFFLING BLADE BASE SHAFT	
1-2-3	146589001	1	-----	LAPPER BASE	
1-2-4	101706001	2	-----	SCREW 6.35	
1-2-5	146590001	1	-----	SPRING BASE	
1-2-6	105163001	2	-----	SCREW 5.95	
1-2-7	110820101	1	-----	TENSION CONTROL STUD	
1-2-8	025770232	1	-----	WASHER 6.35	
1-2-9	144788001	1	-----	SPRING	
1-2-10	144105000	1	-----	TENSION SPRING WASHER	
1-2-11	149566001	1	-----	THREAD TENSION ADJUSTING NUT	
1-2-12	144783001	1	-----	RUFFLING BLADE	
1-2-13	144784001	1	-----	WASHER	
1-2-14	062660712	2	-----	SCREW 318X7	
1-2-15	147933001	1	-----	STUD SCREW 5.95	
1-2-16	145807001	1	-----	RUFFLING BLADE GUIDE	
1-2-17	062680812	1	-----	SCREW 437X8	
1-2-18	148387001	1	-----	RUFFLING PLATE LIFTER	
1-2-19	145810001	1	-----	HANDLE FIXING PLATE	
1-2-20	150553002	1	-----	NUT 5.95	
1-2-21	110230001	1	-----	SCREW 4.37	
1-2-22	105234003	1	-----	NUT 4.37	
1-2-23	145811001	1	-----	SPRING PLATE	
1-2-24	145808001	1	-----	SPRING PLATE	
1-2-25	062680612	2	-----	SCREW 437X6	
1-2-26	144764001	1	-----	FRONT COVER STOPPER SPRING	
1-2-27	060670512	1	-----	SCREW 357X5	
1-2-28	146592001	1	-----	THREAD GUIDE PIPE	

From the library of: Diamond Needle Corp

H. ラフラー装置関係/Ruffling attachment/Kräuselvorrichtung/
 Accessoire pour fronces/Accesorio de fruncido

008, 009

(輸出のみ / ONLY FOR EXPORT)

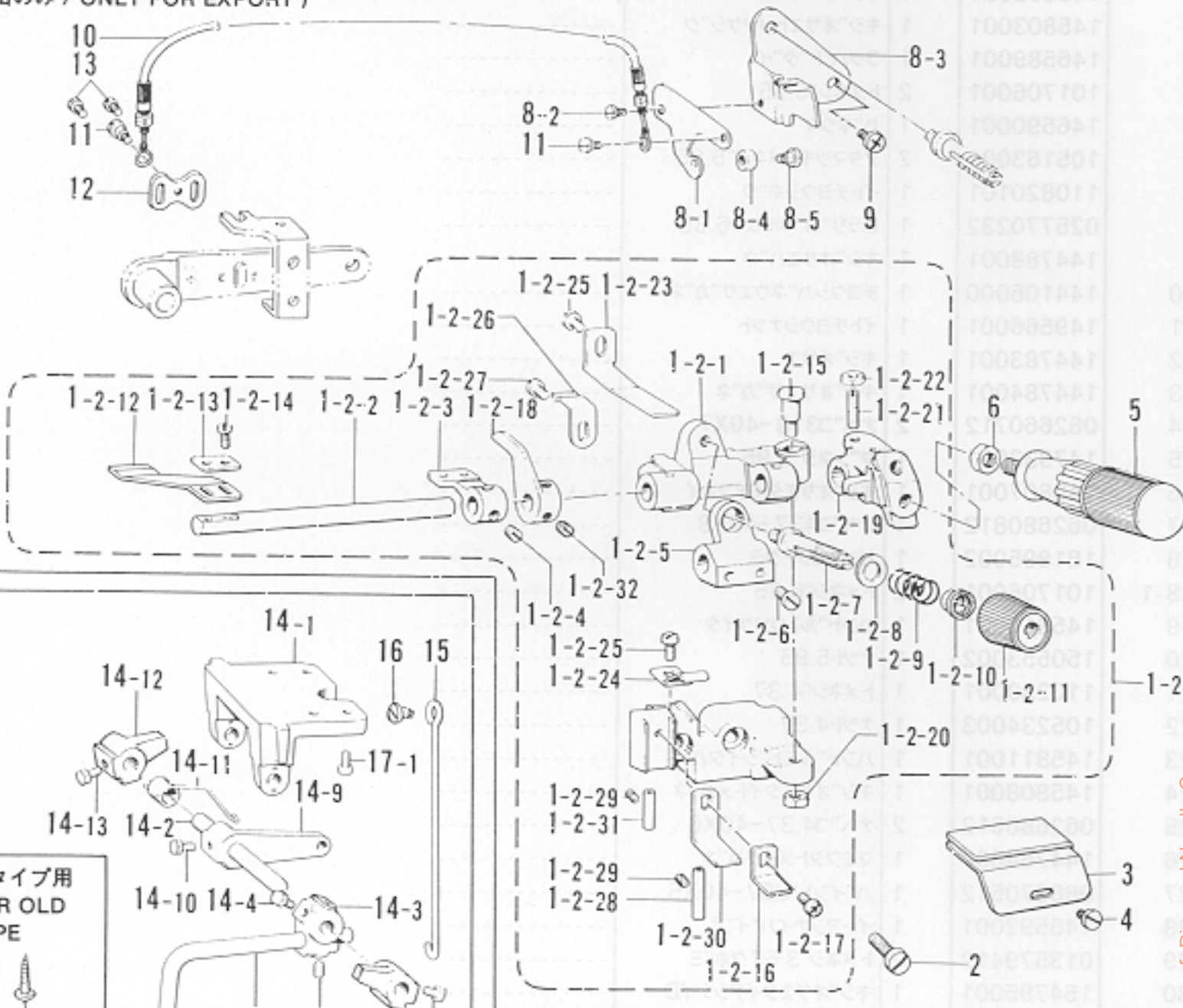

008
009

旧タイプ用
FOR OLD
TYPE



17-2

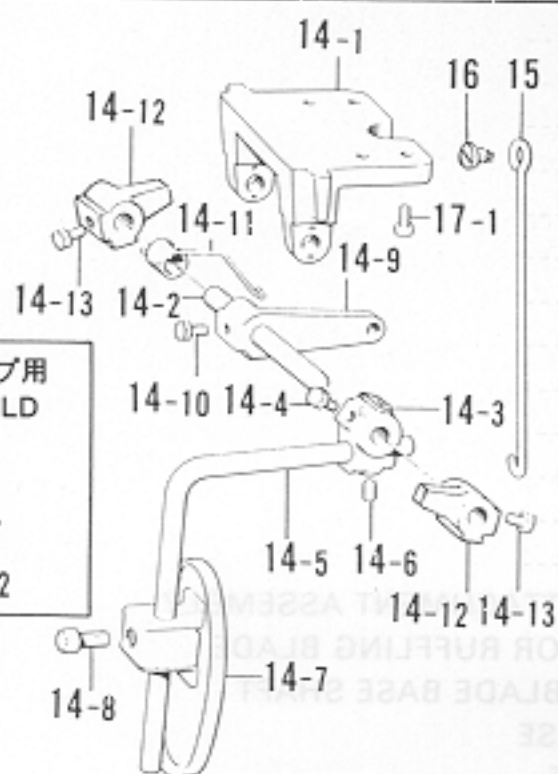

008

(国内のみ / ONLY FOR DOMESTIC)

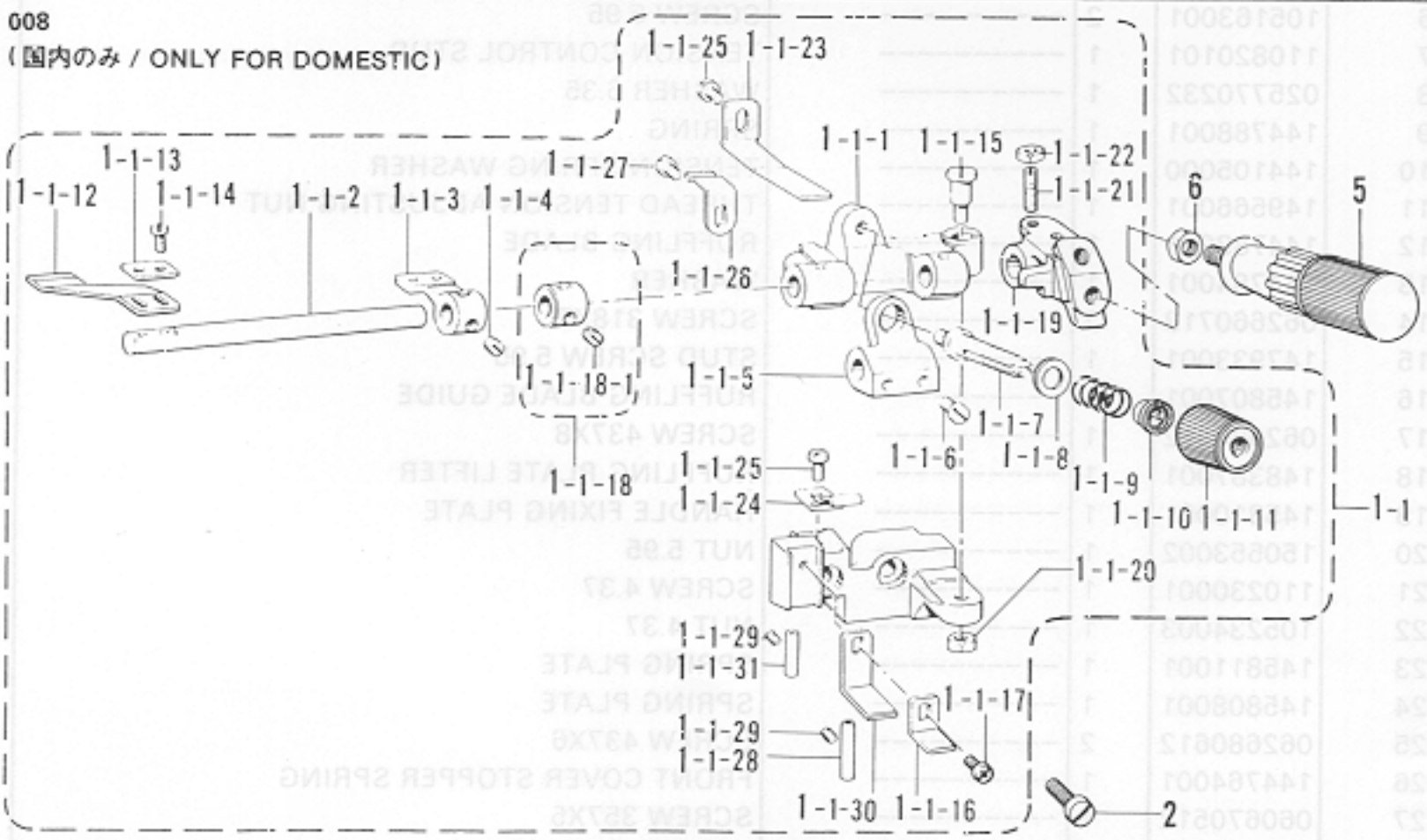

From the library of: Diamond Needle Corp

H. ラフラー装置関係/Ruffling attachment/Kräuselvorrichtung/
 Accessoire pour fronces/Accesorio de fruncido

REF.NO.	CODE	Q'TY	ヒンメイ	NAME OF PARTS	RMKS
1-2-29	013679412	2	-----	SCREW 3.57	
1-2-30	154795001	1	-----	RUFFLING BLADE GUIDE PLATE (LOWER)	
1-2-31	S01614001	1	-----	THREAD GUIDE PIPE	
1-2-32	101706001	2	-----	SCREW 6.35	
2	S01304001	2	シメネジ"6.35X18	SCREW 6.35X18	
3	144793000	1	-----	RUFFLER GUIDE	
4	112751002	1	-----	SCREW 3.57	
5	145809001	1	ハント"ル	HANDLE	
6	150556002	1	ナツト6.35	NUT 6.35	
8	148395001	1	-----	RUFFLING PLATE LIFTER LEVER ASSEMBLY	
8-1	148388001	1	-----	RUFFLING PLATE LIFTER LEVER	
8-2	141514001	1	-----	SCREW	
8-3	148389001	1	-----	PRESSER FOOT LIFTER LEVER SUPPORTER	
8-4	148390001	1	-----	ROLLER	
8-5	112301001	1	-----	STUD SCREW 3.18	
9	062680812	1	-----	SCREW 437X8	
10	148391001	1	-----	FLEXIBLE WIRE ASSEMBLY	
11	141514001	2	-----	SCREW	
12	147672001	1	-----	WIRE SETTING PLATE	
13	062670612	2	-----	SCREW 357X6	
14	155196201	1	サト"ウチヨウセツソウチクミ	DIFFERENTIAL ADJUSTMENT ASSEMBLY	
14-1	155197001	1	ヒサ"アテヨコシ"クウケ	KNEE LIFTER SHAFT BRACKET	
14-2	155198101	1	ヨコシ"ク	KNEE LIFTER SHAFT	
14-3	155199101	1	ヒサ"アテツキ"テ	KNEE LIFTER BRACKET	
14-4	017781012	2	ホ"ルト6.35X10	BOLT 6.35X10	
14-5	148797001	1	ヒサ"アケ"タテシ"クス	KNEE LIFTER BAR (SMALL)	
14-6	014780622	1	アノメネジ"6.35クホ"ミ	SCREW 6.35	
14-7	148798001	1	ヒサ"アテL	KNEE LIFTER PLATE (LARGE)	
14-8	100463001	1	4カクホ"ルト7.94	BOLT 7.94	
14-9	155201101	1	ヒサ"アテレハ"ー	KNEE LIFTER LEVER	
14-10	017781012	2	ホ"ルト6.35X10	BOLT 6.35X10	
14-11	155202001	1	ヒサ"アテレハ"ーハ"ネ	KNEE LIFTER LEVER SPRING	
14-12	155203201	2	ヨコシ"クトメク"	COLLAR	
14-13	017781012	4	ホ"ルト6.35X10	BOLT 6.35X10	
15	155205001	1	ヒサ"アテリンク	CONNECTING BAR	
16	146594001	1	タ"ンネジ"4.76	STUD SCREW 4.76	
17-1	062681012	4	ナヘ"コ437-40X10	SCREW 437X10	
17-2	032422505	4	+マルモクネジ"4.1X25 (キュウタイプ トウフ"ウケヨウ)	SCREW 4.1X25 (FOR OLD TYPE HEAD BRACKET)	

From the library of: Diamond Needle Corp

J. ヒモ案内関係 / Gimp guide mechanism / Schnurführung /
 Mécanisme du guide-fil / Mecanismo guía del hilo

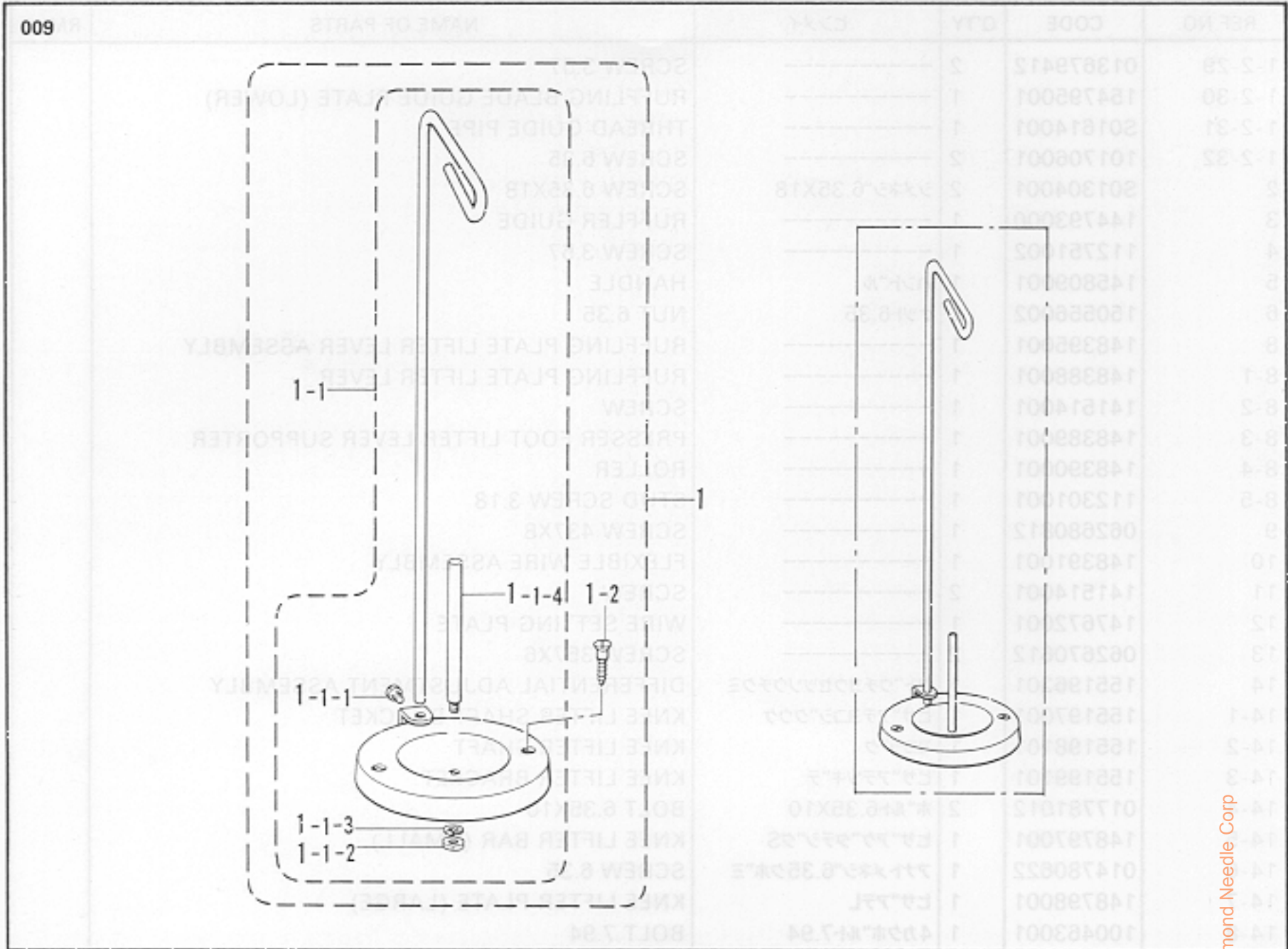

K. テープワインダー関係 / Tape winder mechanism / Bandaufwickelvorrichtung /
 Mécanisme de l'enrouleur de ruban / Mecanismo bobinador de cinta

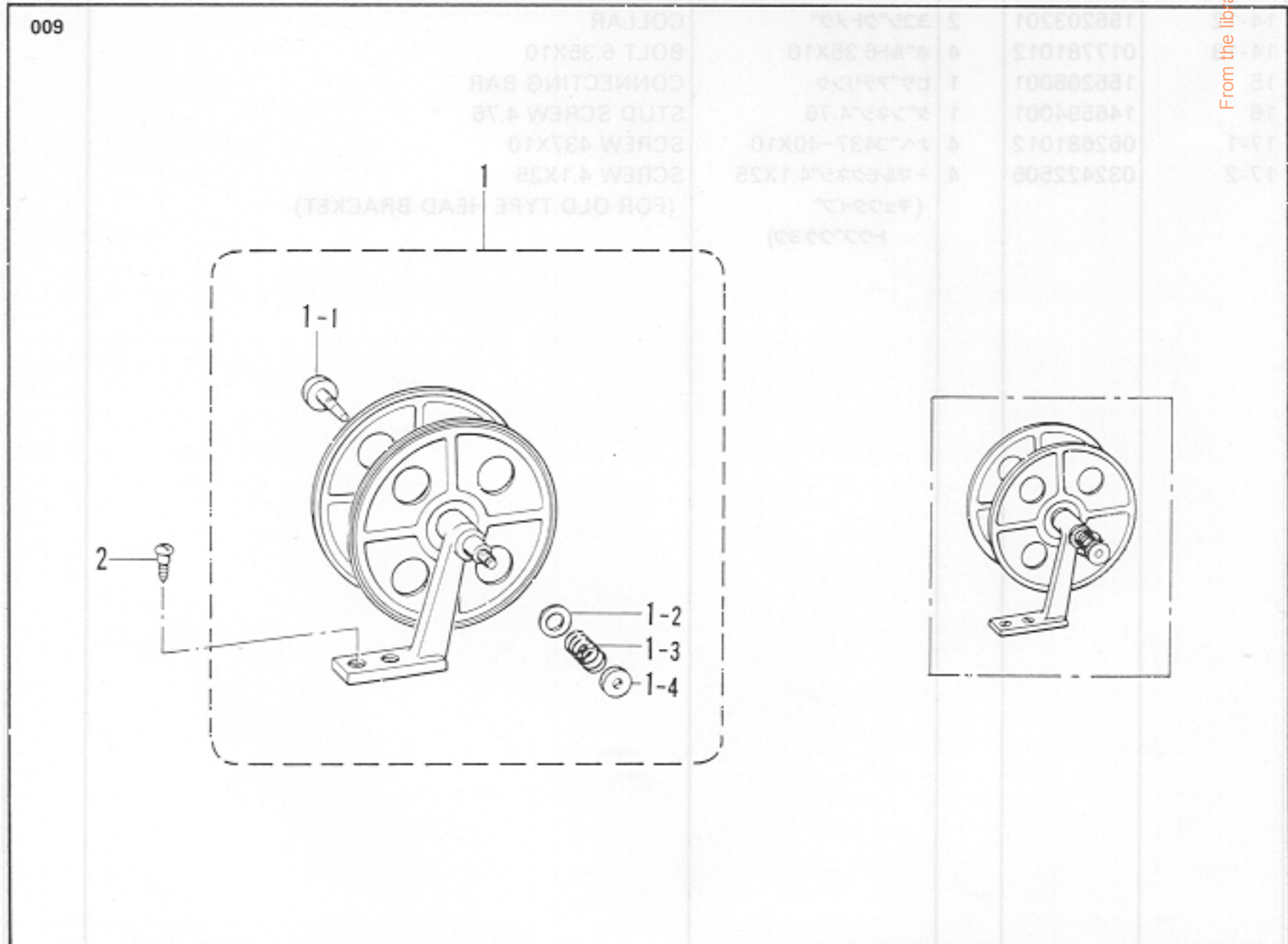

J. ヒモ案内関係 / Gimp guide mechanism / Schnurführung /
 Mécanisme du guide-fil / Mecanismo guía del hilo

REF.NO.	CODE	Q'TY	ヒンメイ	NAME OF PARTS	RMKS
1	181031001	1	-----	COTTON STAND WITH SCREW	
1-1	109854001	1	-----	SPOOL STAND	
1-1-1	100080004	1	-----	SCREW 3.18	
1-1-2	110161003	1	-----	NUT 4.76	
1-1-3	028050242	1	-----	SPRING WASHER 2-5	
1-1-4	100444002	1	-----	SPOOL STUD	
1-2	100447001	2	-----	SCREW 4.5X3.2	

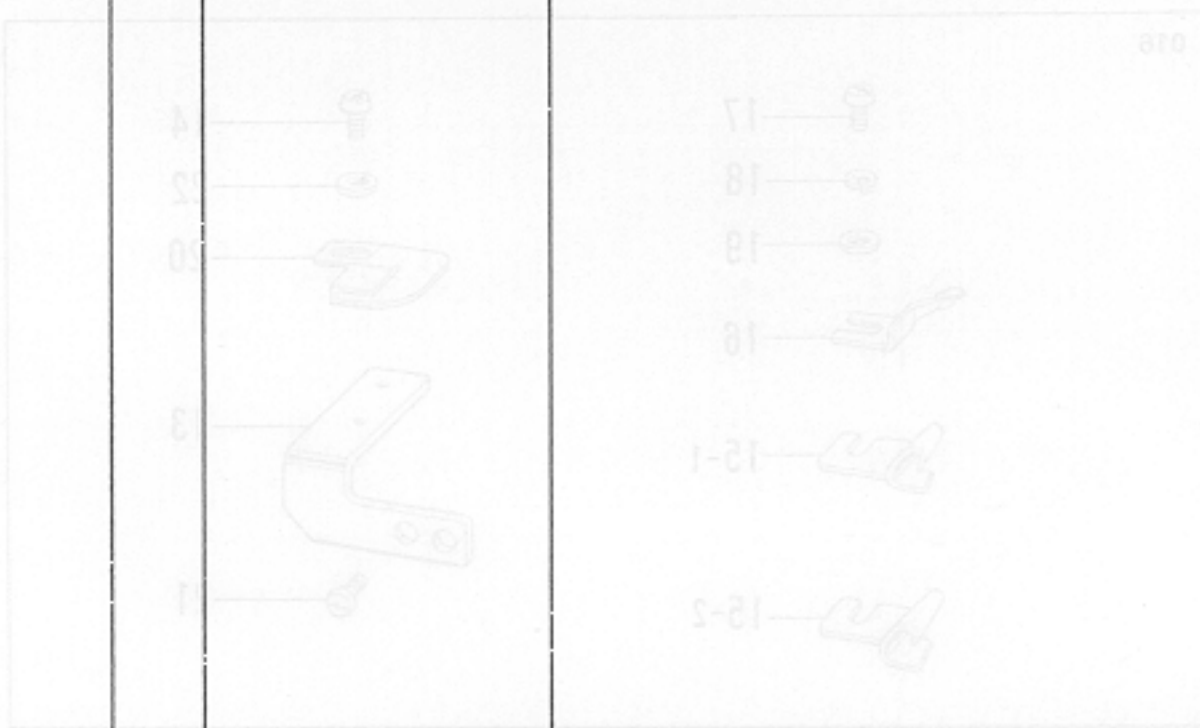

K. テープワインダー関係 / Tape winder mechanism / Bandaufwickelvorrichtung /
 Mécanisme de l'enrouleur de ruban / Mecanismo bobinador de cinta

REF.NO.	CODE	Q'TY	ヒンメイ	NAME OF PARTS	RMKS
1	143767002	1	-----	TAPE WINDER ASSEMBLY	
1-1	143980001	1	-----	THUMB SCREW	
1-2	108494001	1	-----	WASHER	
1-3	108495001	1	-----	SPRING	
1-4	100136001	1	-----	TENSION CONTROL NUT	
2	101118001	2	-----	SCREW 4.5X20	

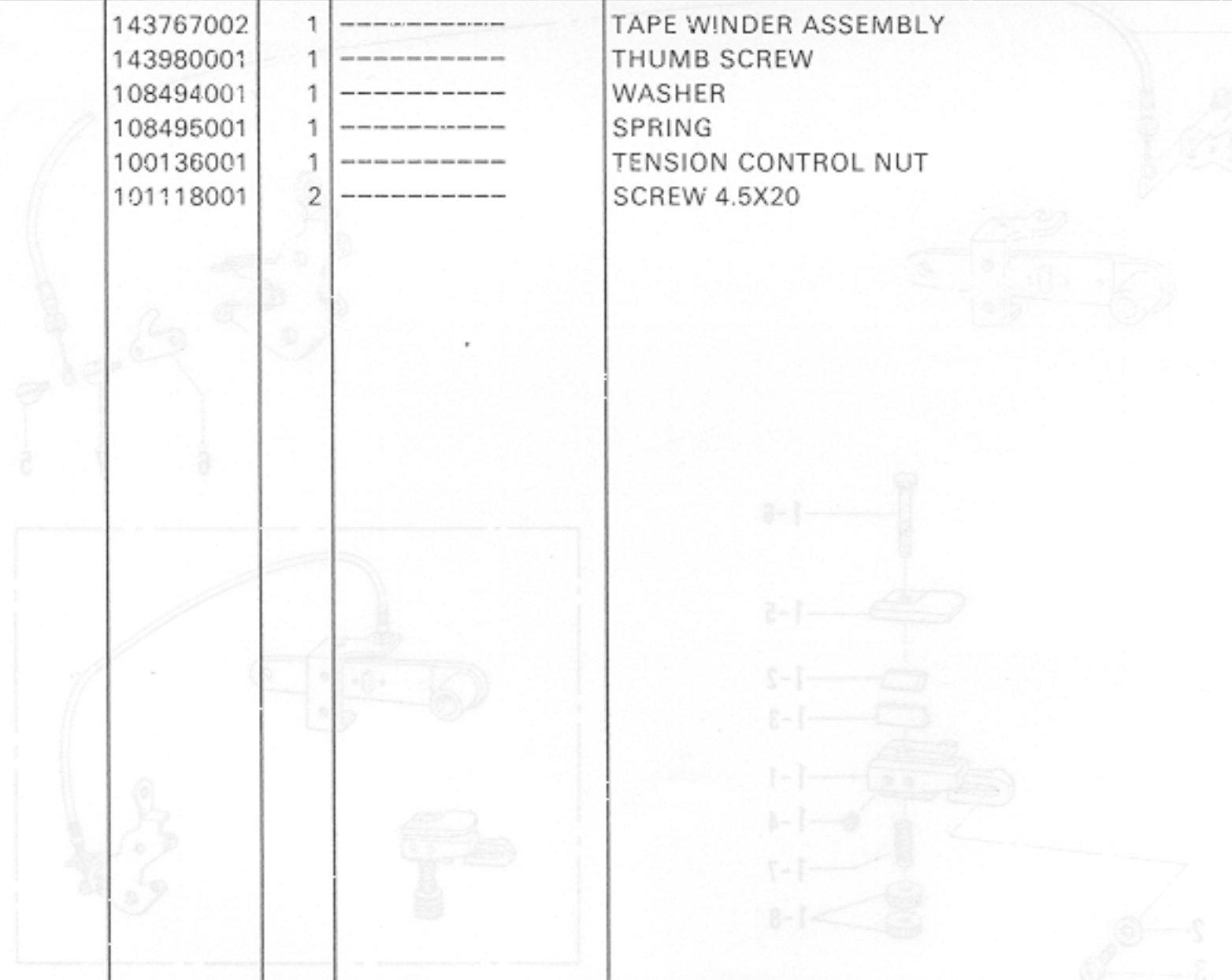

From the library of: Diamond Needle Corp

L. ラッパ-関係 / Lapper mechanism / Falz-Mechanismus /
 Mécanisme à rabat / Mecanismo de solapado

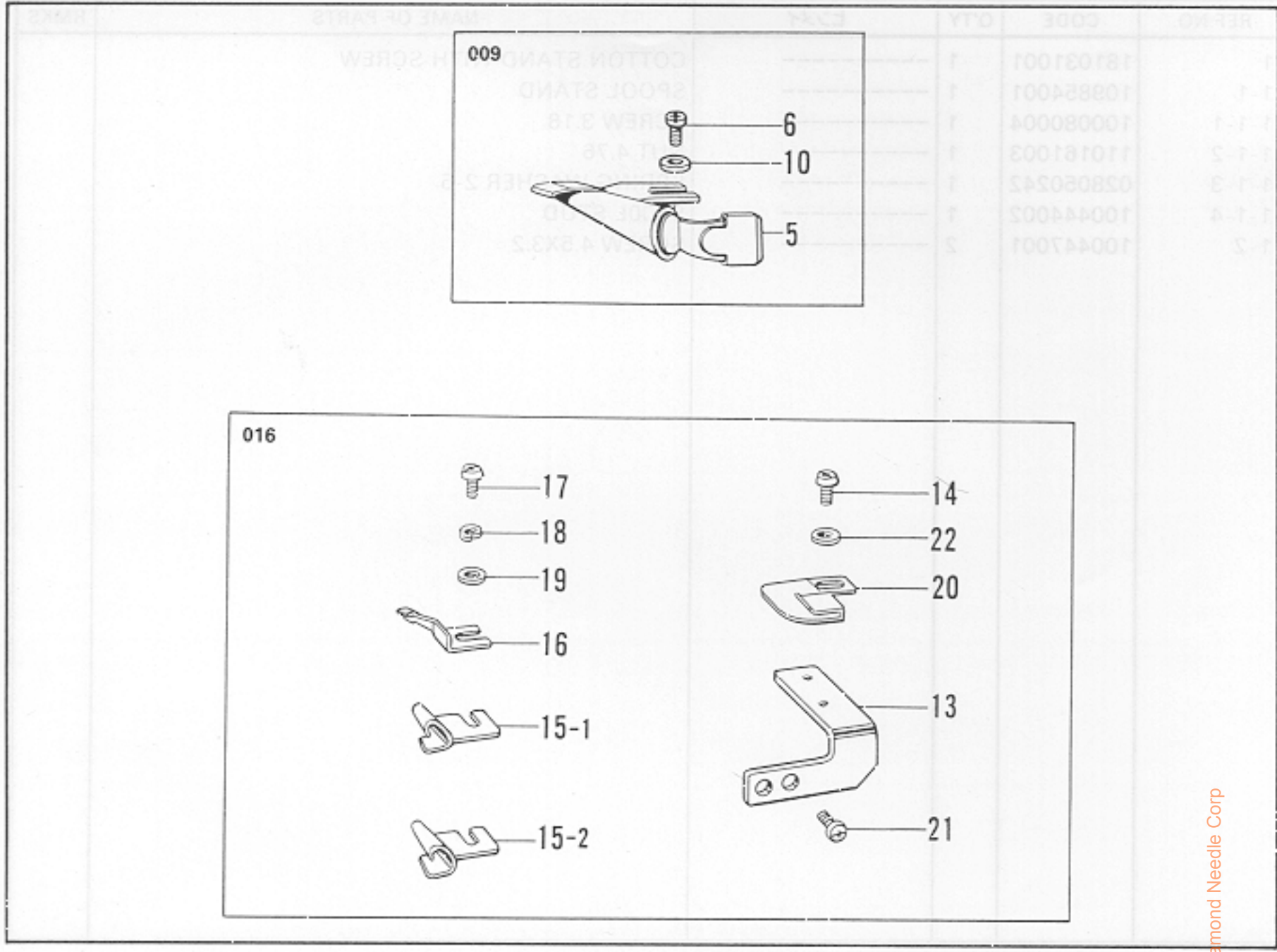

M. バックタック関係 / Back-tacking / Rückwärtsheftvorrichtung / Point d'arrêt / Pespunte de revés

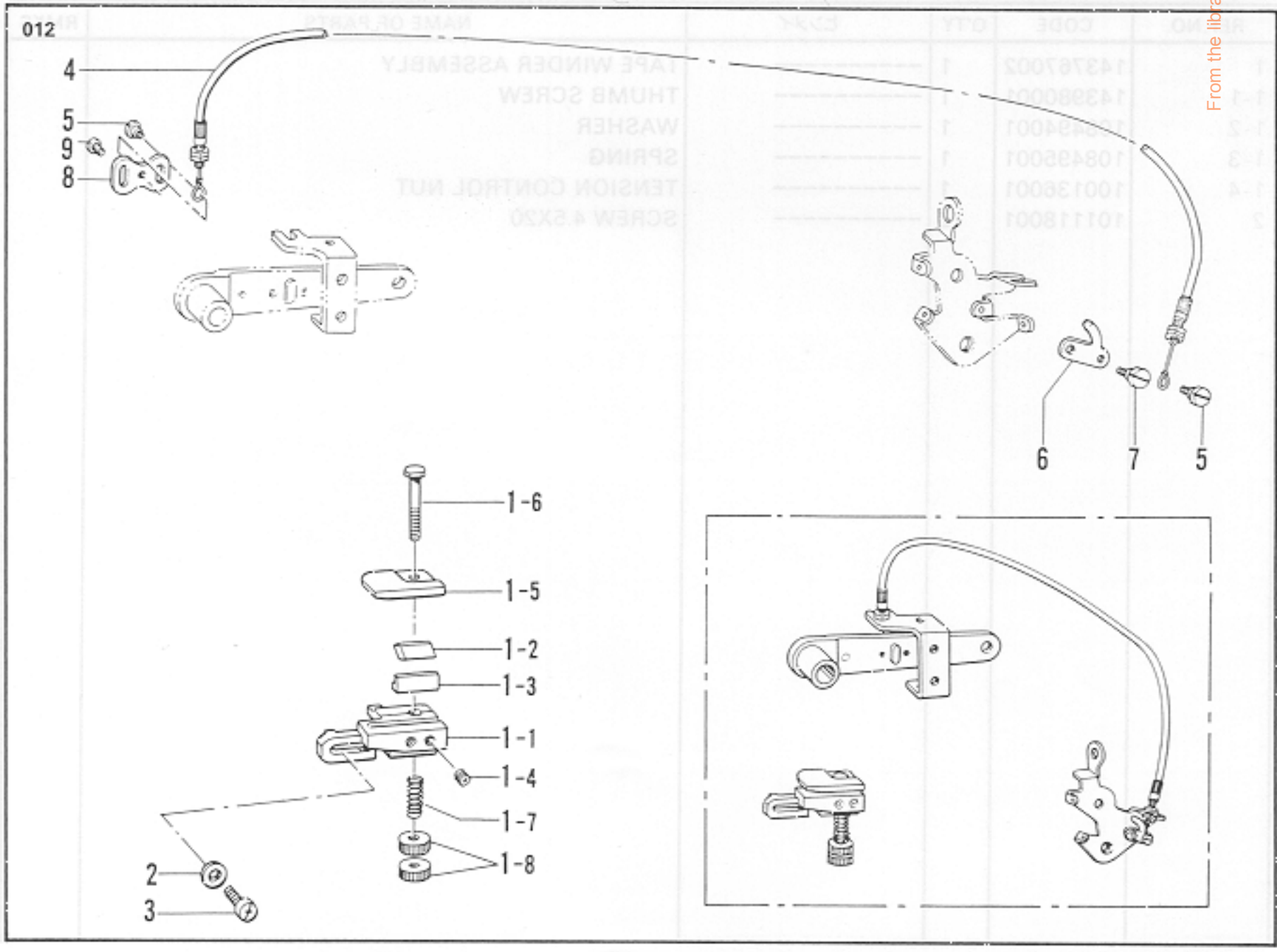

From the library of: Diamond Needle Corp

L. ラッパ-関係/Lapper mechanism/Falz-Mechanismus/
M chanisme   rabat/Mecanismo de solapado

REF.NO.	CODE	Q'TY	ヒンメイ	NAME OF PARTS	RMKS
<パイピングラフ-ヨウ/ FOR RUFFLING WITH PIPING >					
5	147440000	1	-----	LAPPER ASSEMBLY	
6	062680612	2	-----	SCREW 437X6	
10	110735002	2	-----	WASHER	
<ウマキヨウ/ FOR OVER WINDING >					
13	S06012001	1	ラツパト"タイ	WAPPER BASE	
14	060670612	2	ハ"イント"357-40X6	SCREW 357X6	
15-1	S06016000	1	ラツパ"4クミ <4MMヨウ>	WAPPER ASSEMBLY <4MM>	
15-2	S06018000	1	ラツパ"5クミ <5MMヨウ>	WAPPER ASSEMBLY <5MM>	
16	S06020001	1	ツメ	TONGUE	
17	062670612	1	ナヘ"コ357-40X6	SCREW 357X6	
18	028350242	1	ハ"ネサ"ガ"ネ2-3.5	SPRING WASHER 2-3.5	
19	105161003	1	サ"ガ"ネ	WASHER	
20	S06021000	1	キシ"アンナイ	RUFFLER GUIDE	
21	062670612	1	ナヘ"コ357-40X6	SCREW 357X6	
22	105161003	1	サ"ガ"ネ	WASHER	

M. バックタック関係/Back-tacking/R ckw rshftvorrichtung/Point d'arr t/Pespunte de rev s

REF.NO.	CODE	Q'TY	ヒンメイ	NAME OF PARTS	RMKS
1	S09232101	1	カエシヌイオサイクミ	BACK-TACK PRESSER ASSEMBLY	
1-1	S09233001	1	カエシヌイメスト"タイ	BACK-TACK BLADE HOLDER	
1-2	S09234001	1	カエシヌイメス	BACK-TACK KNIFE	
1-3	S09235001	1	カエシヌイメスオサイ	BACK-TACK KNIFE PRESSER	
1-4	146427001	2	アナトメネシ"3.18クホ"ミ	SCREW 3.18	
1-5	S11144001	1	カエシヌイオサイイタ	BACK-TACK PRESSER PLATE	
1-6	S09237101	1	オサイイタオシホ"ウ	PRESSER PLATE SHAFT	
1-7	116794001	1	オシハ"ネ	SPRING	
1-8	107682001	2	イトマキチヨウシナツト	TENSION CONTROL NUT	
2	025350132	2	ヒラサ"ガ"ネシヨウ	WASHER	
3	062671012	2	ナヘ"コ357-40X10	SCREW 357X10	
4	147480001	1	フレキシブルワイヤクミ	FLEXIBLE WIRE ASSEMBLY	
5	141514001	2	ハサミダ"ンネシ"	STUD SCREW	
6	147483001	1	イトユルメテコ	THREAD RELEASE LEVER	
7	141514001	1	ハサミダ"ンネシ"	STUD SCREW	
8	147672001	1	ワイヤトリツケイタ	WIRE SETTING PLATE	
9	062670612	2	ナヘ"コ357-40X6	SCREW 357X6	

From the library of: Diamond Needle Corp

N. 裾引定規関係 / Blind hemming Attachment / Blindsaumstichvorrichtung /
 Accessoire pour ourlages en points invisibles / Dispositivo de orillado con punto de surjote

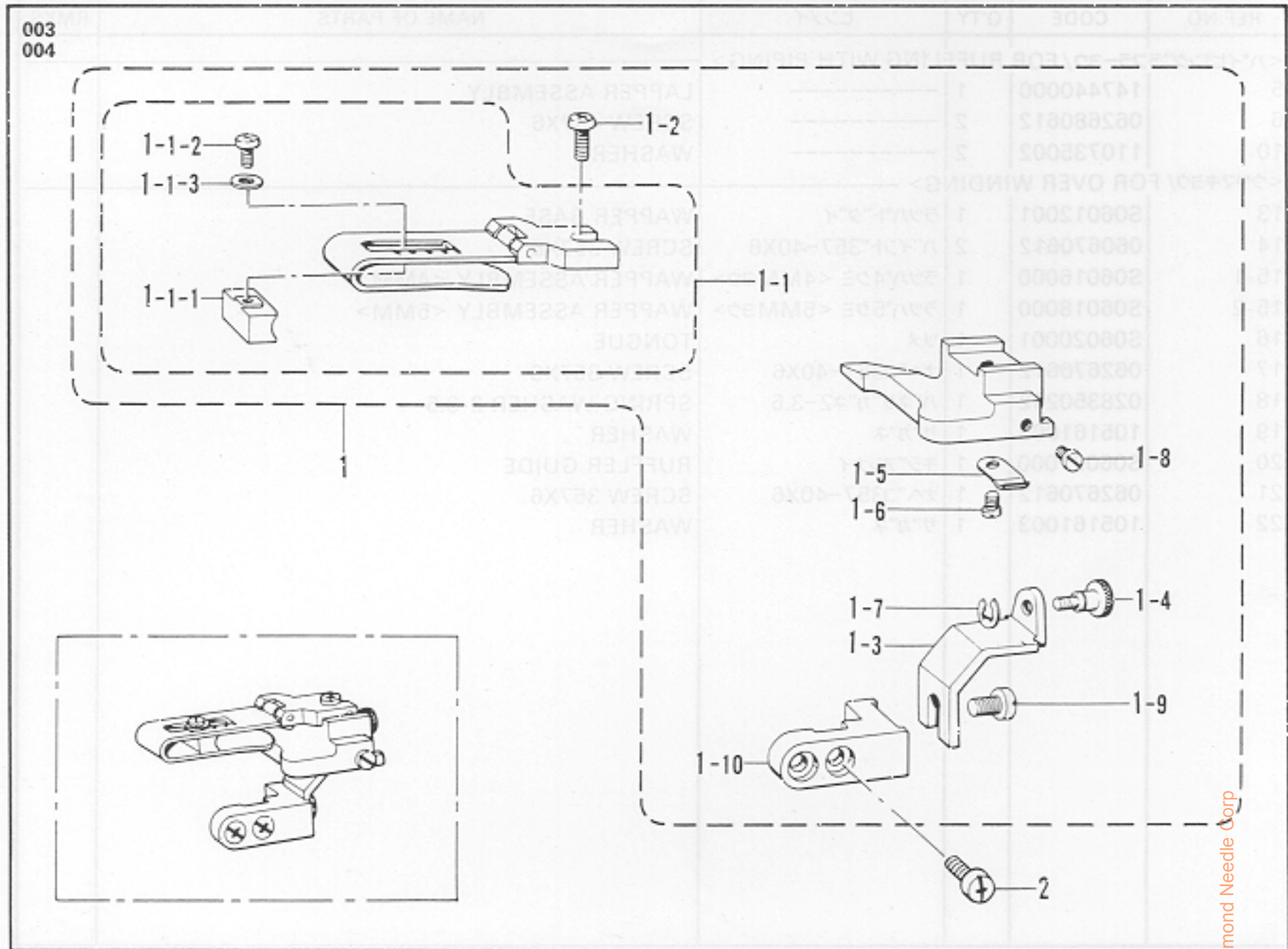

P. 縁カガリ定規関係 / Serging Attachment / Überwendlichvorrichtung /
 Accessoire pour couture sur tissus serges / Dispositivo de dobladillo para puntada invisible

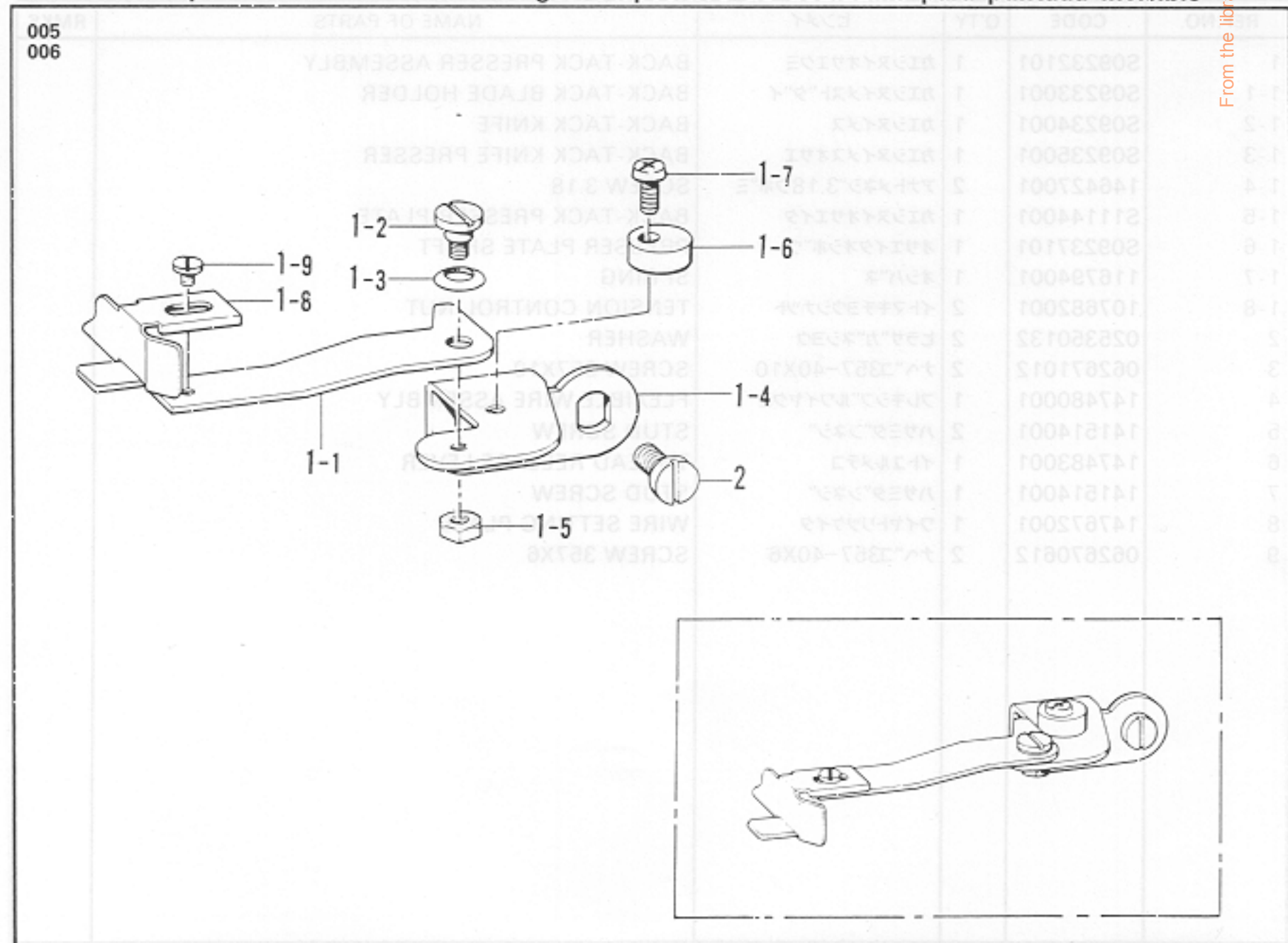

From the library of: Diamond Needle Corp

N. 裾引定規関係/Blind hemming Attachment/Blindsaumstichvorrichtung/
 Accessoire pour ourlages en points invisibles/Dispositivo de orillado con punto de surjote

REF.NO.	CODE	Q'TY	ヒンメイ	NAME OF PARTS	RMKS
1	147710101	1	スソヒキシ"ヨウキ"クミ	EDGE HEMMING RULER ASSEMBLY	
1-1	151173101	1	シ"ヨウキ"クミ	RULER ASSEMBLY	
1-1-1	150339001	1	シ"ヨウキ"チヨウセツタイ	BLIND HEMMING RULER ADJUSTER	
1-1-2	062660412	1	ナヘ"コ318-40X4	SCREW 318X4	
1-1-3	025030232	1	ヒラサ"カ"ネチユウ3	WASHER 3	
1-2	060670812	1	ハ"イント"357-40X8	SCREW 3.57X8	
1-3	147712001	1	シ"ヨウキ"トリツケタイ	RULER FITTING HOLDER	
1-4	146759001	1	シ"ヨウキ"チヨウセツネシ"	ADJUSTING SCREW	
1-5	147713001	1	イタハ"ネ	SPRING PLATE	
1-6	062670412	1	ナヘ"コ357-40X4	SCREW 357X4	
1-7	048030342	1	トメウE3	STOP RING E3	
1-8	111443003	1	マルヒラトメネシ"3.57	SET SCREW 3.57	
1-9	062680712	1	ナヘ"コ437-40X7	SCREW 437X7	
1-10	146760001	1	トリツケタイ"イササエ	RULER FITTING HOLDER SUPPORTER	
2	062670612	2	ナヘ"コ357-40X6	SCREW 357X6	

P. 縁カガリ定規関係/Serging Attachment/Überwendlichvorrichtung/
 Accessoire pour couture sur tissus serges/Dispositivo de dobladillo para puntada invisible

REF.NO.	CODE	Q'TY	ヒンメイ	NAME OF PARTS	RMKS
1	146761001	1	フチカガ"リシ"ヨウキ"クミ	EDGE GUIDE ASSEMBLY	
1-1	146596001	1	シ"ヨウキ"トリツケイタ	EDGE GUIDE SETING PLATE	
1-2	146597101	1	タ"ンネシ"4.37	STUD SCREW 4.37	
1-3	146598001	1	ハ"ネサ"カ"ネ	SPRING WASHER	
1-4	146599001	1	シ"ヨウキ"トリツケイタササエ	EDGE GUIDE SUPPORTER	
1-5	021680202	1	ナツト2シユ4.37	NUT 4.37	
1-6	S03321001	1	オサエウテ"ストツハ"	PRESSER ARM STOPPER	
1-7	062710812	1	ナヘ"コ476-32X8	SCREW 476X8	
1-8	146762001	1	フチカガ"リシ"ヨウキ"	EDGE GUIDE	
1-9	S01297001	1	シメネシ"3.57X3.5	SCREW 3.57X3.5	
2	110201001	2	シメネシ"6.35	SCREW 6.35	

From the library of: Diamond Needle Corp

Q. 上ルーバ関係/Over looper mechanism/Oberen Greifer/
 Mécanisme du boucleur supérieur/Mecanismo del presilladora superior

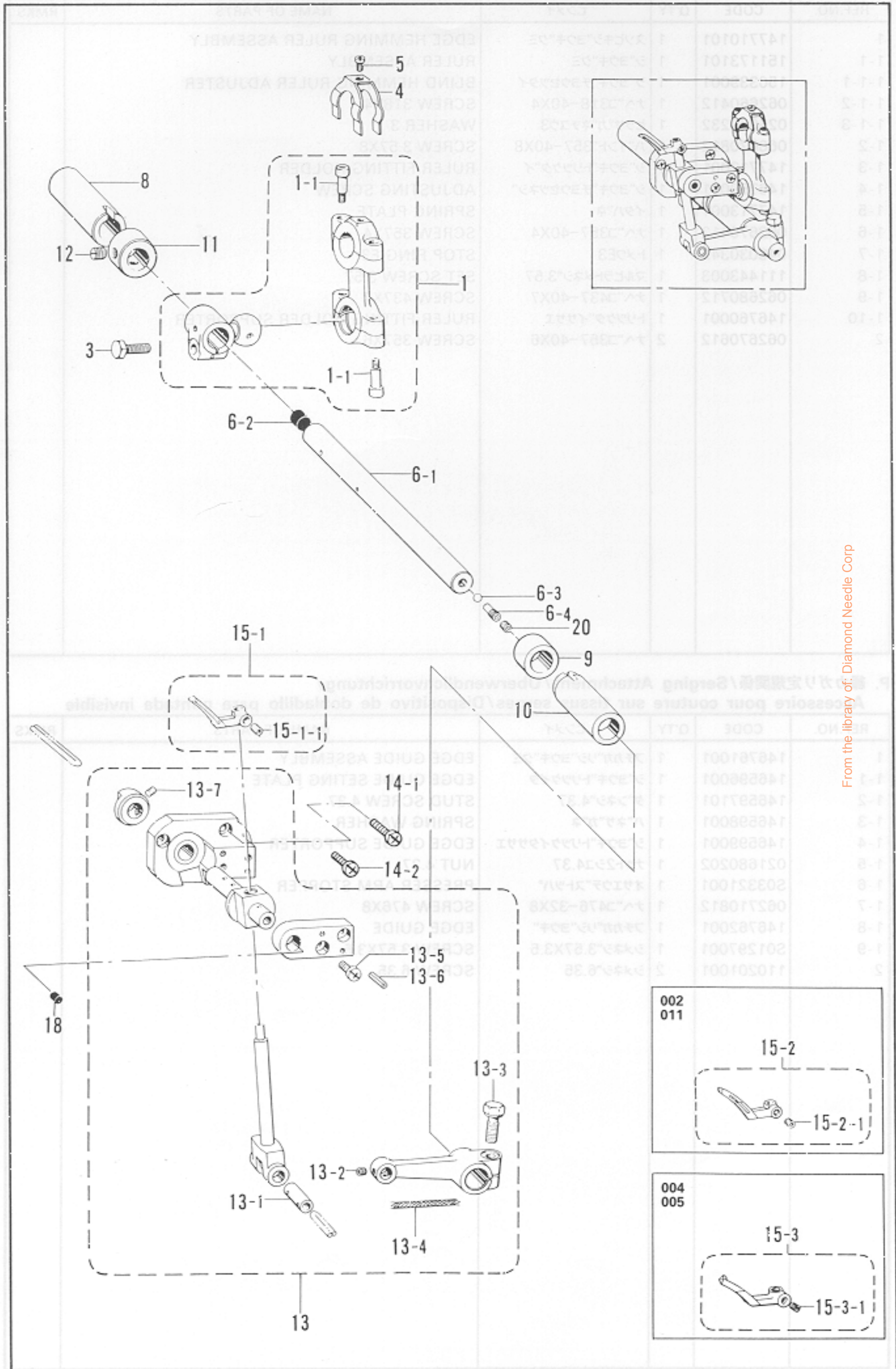

From the library of: Diamond Needle Corp

Q. 上ルーバ関係/Over looper mechanism/Oberen Greifer/
Mécanisme du boucleur supérieur/Mecanismo del presilladora superior

REF.NO.	CODE	Q'TY	ヒンメイ	NAME OF PARTS	RMKS
1	144025001	1	ウフルーパ"ロット"クミ	OVER LOOPER CONNECTING ROD ASSEMBLY	※
1-1	148425001	4	アナボ"ルト4.37X14	BOLT 4.37X14	
3	017771412	1	ボ"ルト6.35X14	BOLT 6.35X14	
4	110704001	1	ウフルーパ"ロット"フレ"ト"メ	LOOPER CONNECTING ROD STOPPER	
5	062660412	1	ナヘ"コ318-40X4	SCREW 318X4	
6	S06294001	1	ウフルーパ"シ"ククミ	OVER LOOPER SHAFT ASSEMBLY	
6-1	148033001	1	ウフルーパ"シ"ク	OVER LOOPER SHAFT	
6-2	140327001	1	コ"ムセン	OIL CAP	
6-3	071023850	1	コウキユウ3/32	STEEL BALL 3/32"	
6-4	148034001	1	オイルチヨウセツネシ"	OIL ADJUSTING SCREW	
8	144029000	1	ウフルーパ"シ"クメタルB	OVER LOOPER SHAFT BUSHING (REAR)	
9	146602001	1	ウフルーパ"シ"クカラ-	THRUST COLLAR	
10	144031000	1	ウフルーパ"シ"クメタルF	OVER LOOPER SHAFT BUSHING (FRONT)	
11	146581001	1	セツトカラ-	SET COLLAR	
12	100260001	2	トメネシ"5.95	SCREW 5.95	
13	*	1	ウフルーパ"キ"コウクミ	OVER LOOPER ASSEMBLY	
13-1	148379001	1	ウフルーパ"ウ"デ"シ"ク	OVER LOOPER HOLDING SHAFT	
13-2	148294001	1	アナトメネシ"3.57クホ"ミ	SCREW 3.57	
13-3	149170001	1	ボ"ルト6.35X16	BOLT 6.35X16	
13-4	140416000	1	クミヒモ	WICK	
13-5	062681012	2	ナヘ"コ437-40X10	SCREW 437X10	
13-6	047301440	2	スプリング"ピン"AW3	SPRING PIN AW3	
13-7	014680422	2	アナトメネシ"4.37クホ"ミ	SCREW 4.37	
14-1	062680712	1	ナヘ"コ437-40X7	SCREW 437X7	
14-2	S10774001	2	ナヘ"コ437-40X7	SCREW 437X7	
15-1	147934001	1	ウフルーパ"ネシ"ツキ	OVER LOOPER WITH SCREW	
15-1-1	014680422	1	アナトメネシ"4.37クホ"ミ	SCREW 4.37	
15-2	159686001	1	ウフルーパ"ネシ"ツキ <ハ"ルキ-ヨウ>	OVER LOOPER WITH SCREW <FOR BULKY>	
15-2-1	014680422	1	アナトメネシ"4.37クホ"ミ	SCREW 4.37	
15-3	147935001	1	カキ"ルー"パ"ネシ"ツキ <2ホ"ンイトヨウ>	OVER SPREADER WITH SCREW <2 THREADS>	
15-3-1	014680422	1	アナトメネシ"4.37クホ"ミ	SCREW 4.37	
18	159101000	1	メクラセン	OIL CAP	
20	148294001	1	アナトメネシ"3.57クホ"ミ	SCREW 3.57	



From the library of: Diamond Needle Corp

※クドウジクAクミ (B-1, D-1, Q-1, R-1) 146915-001

※ Crank Shaft (A) Assembly (B-1, D-1, Q-1, R-1) 146915-001

R. 下ルーバ関係 / Under looper mechanism / Unterer Greifer /
 Mécanisme du boucleur inférieur / Mecanismo del presilladora inferior

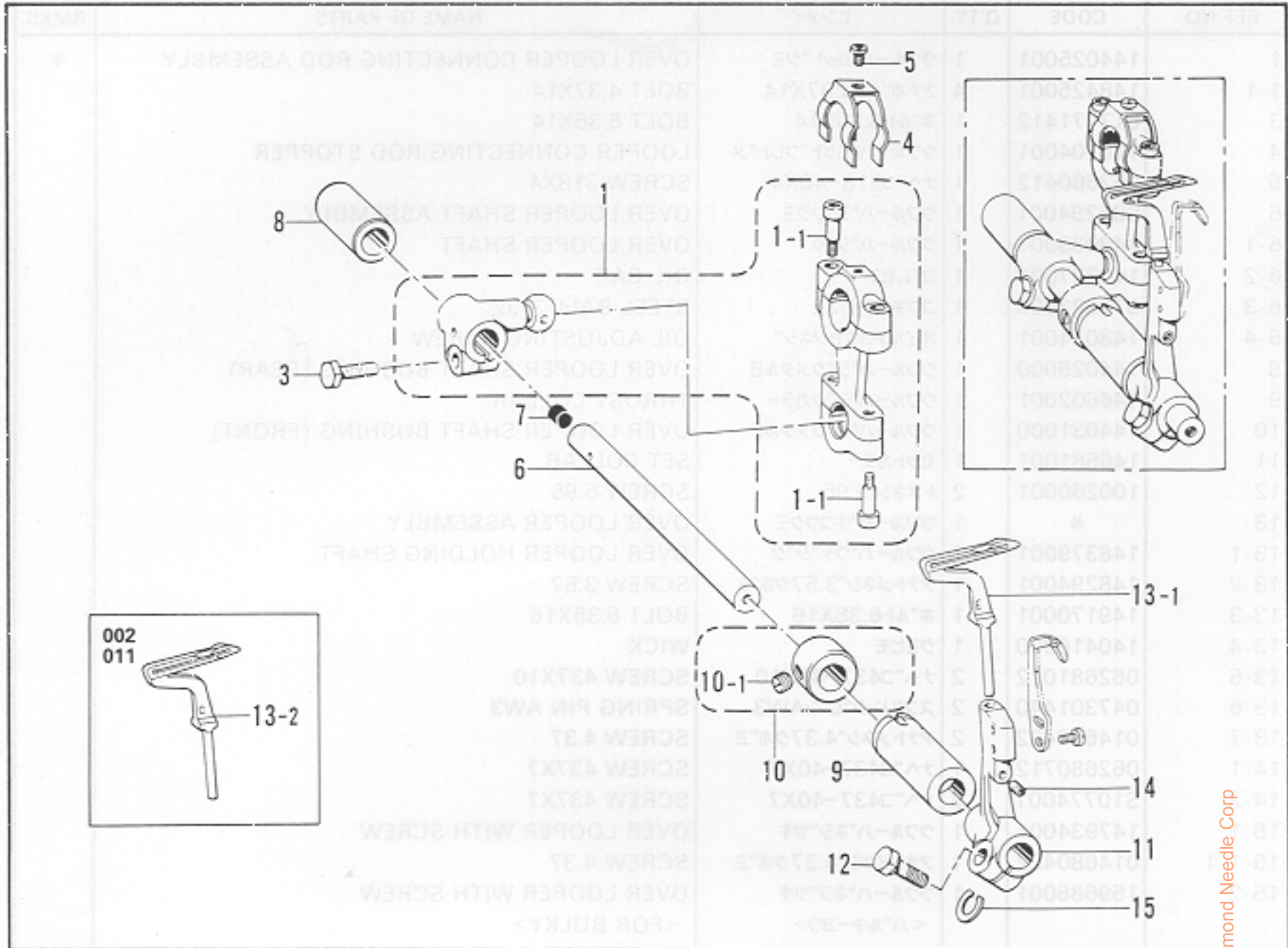

From the library of: Diamond Needle Corp

R. 下ルーパ関係/Under looper mechanism/Unterer Greifer/
 Mécanisme du boucleur inférieur/Mecanismo del presilladora inferior

REF.NO.	CODE	Q'TY	ヒンメイ	NAME OF PARTS	RMKS
1	144044001	1	シタル-ハットクミ	UNDER LOOPER CONNECTING ROD ASSEMBLY	※
1-1	148425001	4	アナボルト4.37X14	BOLT 4.37X14	
3	017771612	1	ボルト6.35X16	BOLT 6.35X16	
4	110704001	1	ウフル-ハットフレトメ	LOOPER CONNECTING ROD STOPPER	
5	062660412	1	ナベコ318-40X4	SCREW 318X4	
6	146614001	1	シタル-ハシク	UNDER LOOPER SHAFT	
7	140327001	1	ゴムセン	OIL CAP	
8	146615000	1	シタル-ハシクメタルB	UNDER LOOPER SHAFT BUSHING (REAR)	
9	146616000	1	シタル-ハシクメタルF	UNDER LOOPER SHAFT BUSHING (FRONT)	
10	180323001	1	シタジクセットカラークミ	LOWER SHAFT SET COLLAR ASSEMBLY	
10-1	013760612	2	トメネジ5.95クホミ	SCREW 5.95	
11	146617001	1	シタル-ハトリツケダイ	UNDER LOOPER HOLDER	
12	149171001	1	ボルト5.56X14	BOLT 5.56X14	
13-1	S01248101	1	シタル-ハ	UNDER LOOPER	
13-2	159884101	1	シタル-ハ<ハルキ-ヨウ>	UNDER LOOPER <FOR BULKY>	
14	014680422	1	アナトメネジ4.37クホミ	SCREW 4.37	
15	148782001	1	スペーサ	SPACER	

※クドウジクAクミ (B-1, D-1, Q-1, R-1) 146915-001

※ Crank Shaft (A) Assembly (B-1, D-1, Q-1, R-1) 146915-001

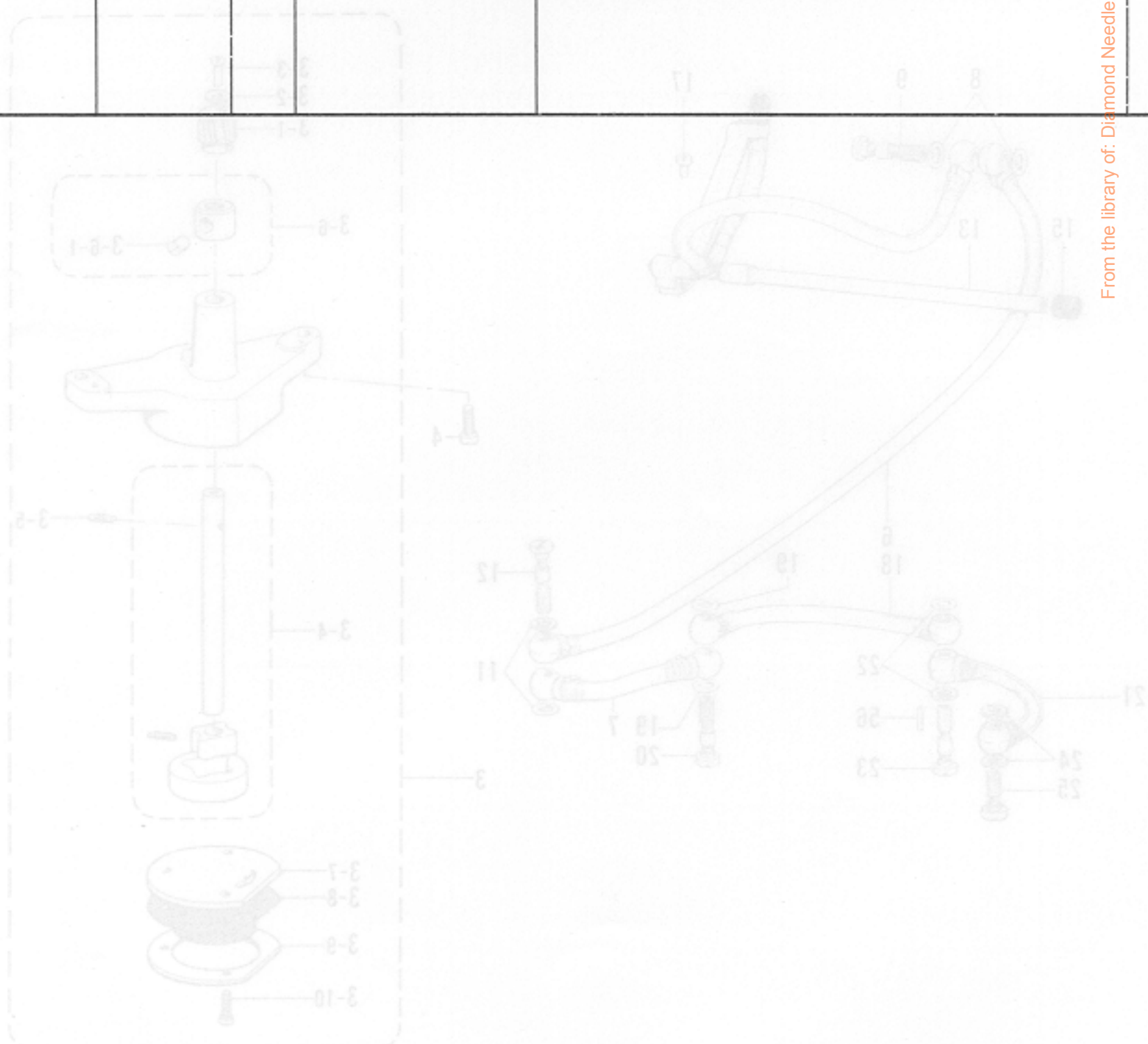

From the library of: Diamond Needle Corp

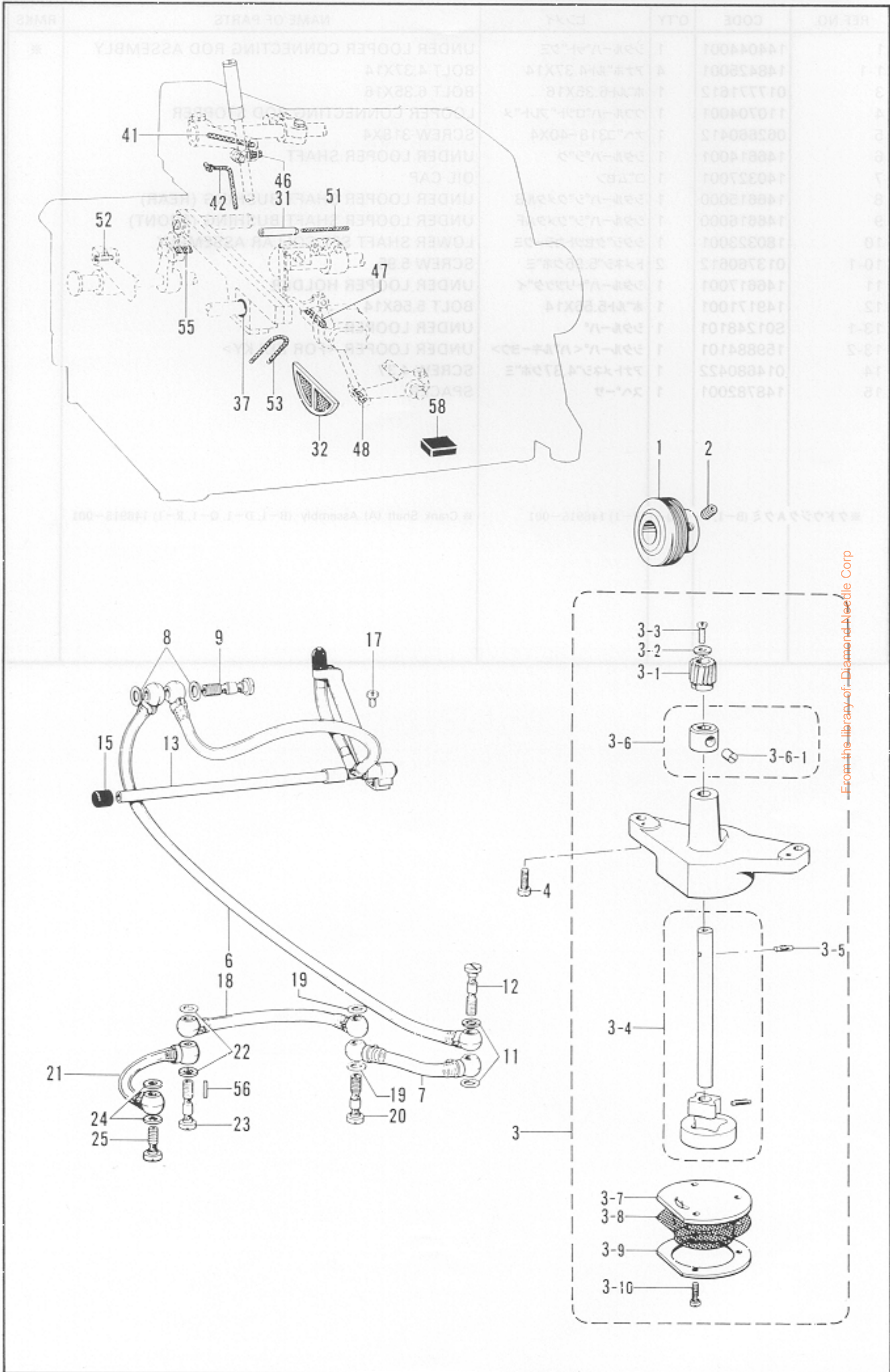

From the library of Diamond Needle Corp

S. 給油・潤滑関係/Lubrication/Schmierung/Lubrication/Lubricación

REF.NO.	CODE	Q'TY	品名	NAME OF PARTS	RMKS
1	146647001	1	ウーム	WORM	
2	014770622	2	アトメネジ"6.35クホ"ミ	SCREW 6.35	
3	147521001	1	トロコイト"ポンプ"クミ	PUMP ASSEMBLY	
3-1	144619000	1	ウームホイール	WORM WHEEL	
3-2	025350332	1	ヒラサ"ガ"ネタ"イ3.5	WASHER 3.5	
3-3	062670812	1	ナヘ"コ357-40X8	SCREW 357X8	
3-4	147523001	1	ポンプロータークミ	PUMP INNER ROTER ASSEMBLY	
3-5	144622001	1	ミゾ"ツキピンE"カタ	DOWEL PIN (E)	
3-6	181995001	1	セットカラークミ	SET COLLAR ASSEMBLY	
3-6-1	101706001	2	トメネジ"6.35	SCREW 6.35	
3-7	147527001	1	ポンプフタ	PUMP COVER	
3-8	147528100	1	ロカモウ	OIL FILTER GAUZE	
3-9	147529001	1	ロカモウオサエ	OIL FLANGE FILTER	
3-10	062671012	3	ナヘ"コ357-40X10	SCREW 357X10	
4	062711212	2	ナヘ"コ476-32X12	SCREW 476X12	
6	140780101	1	ビ"ニルチューブ"クミ	VINYL TUBE ASSEMBLY	
7	140779101	1	ビ"ニルチューブ"クミ	VINYL TUBE ASSEMBLY	
8	112348001	2	ハ"ツキン	PACKING	
9	112364001	1	ハイユ"パイプ"ツキ"テネジ"	SCREW	
11	112348001	2	ハ"ツキン	PACKING	
12	112364001	1	ハイユ"パイプ"ツキ"テネジ"	SCREW	
13	146636201	1	ロット"オイル"パイプ"クミ	MAIN OIL PIPE ASSEMBLY	
15	140325001	1	ゴムセン	OIL CAP	
17	062670612	1	ナヘ"コ357-40X6	SCREW 357X6	
18	140778101	1	ビ"ニルチューブ"クミ	VINYL TUBE ASSEMBLY	
19	112348001	2	ハ"ツキン	PACKING	
20	112364001	1	ハイユ"パイプ"ツキ"テネジ"	SCREW	
21	147211101	1	ビ"ニルチューブ"クミ	VINYL TUBE ASSEMBLY	
22	112348001	2	ハ"ツキン	PACKING	
23	112364001	1	ハイユ"パイプ"ツキ"テネジ"	SCREW	
24	112348001	2	ハ"ツキン	PACKING	
25	112359001	1	ハイユ"パイプ"ツキ"テネジ"	SCREW	
31	147217000	1	オイル"パイプ"	OIL PIPE	
32	145664000	1	オイル"フィルター"	OIL FILTER	
37	114294001	1	O"リング"	O RING	
41	140418000	1	クミ"ヒモ"	WICK	
42	150307000	1	クミ"ヒモ"	WICK	
46	140415000	2	クミ"ヒモ"	WICK	
47	140317000	1	クミ"ヒモ"	WICK	
48	140417000	1	クミ"ヒモ"	WICK	
51	112735000	1	クミ"ヒモ"	WICK	
52	147318000	1	ピン	PIN	
53	147361000	1	クミ"ヒモ"	WICK	
55	147363000	1	フェルト	FELT	
56	147318000	1	ピン	PIN	
58	112525000	1	シユウシ"ン"マグ"ネット	MAGNET	

From the library of: Diamond Needle Corp

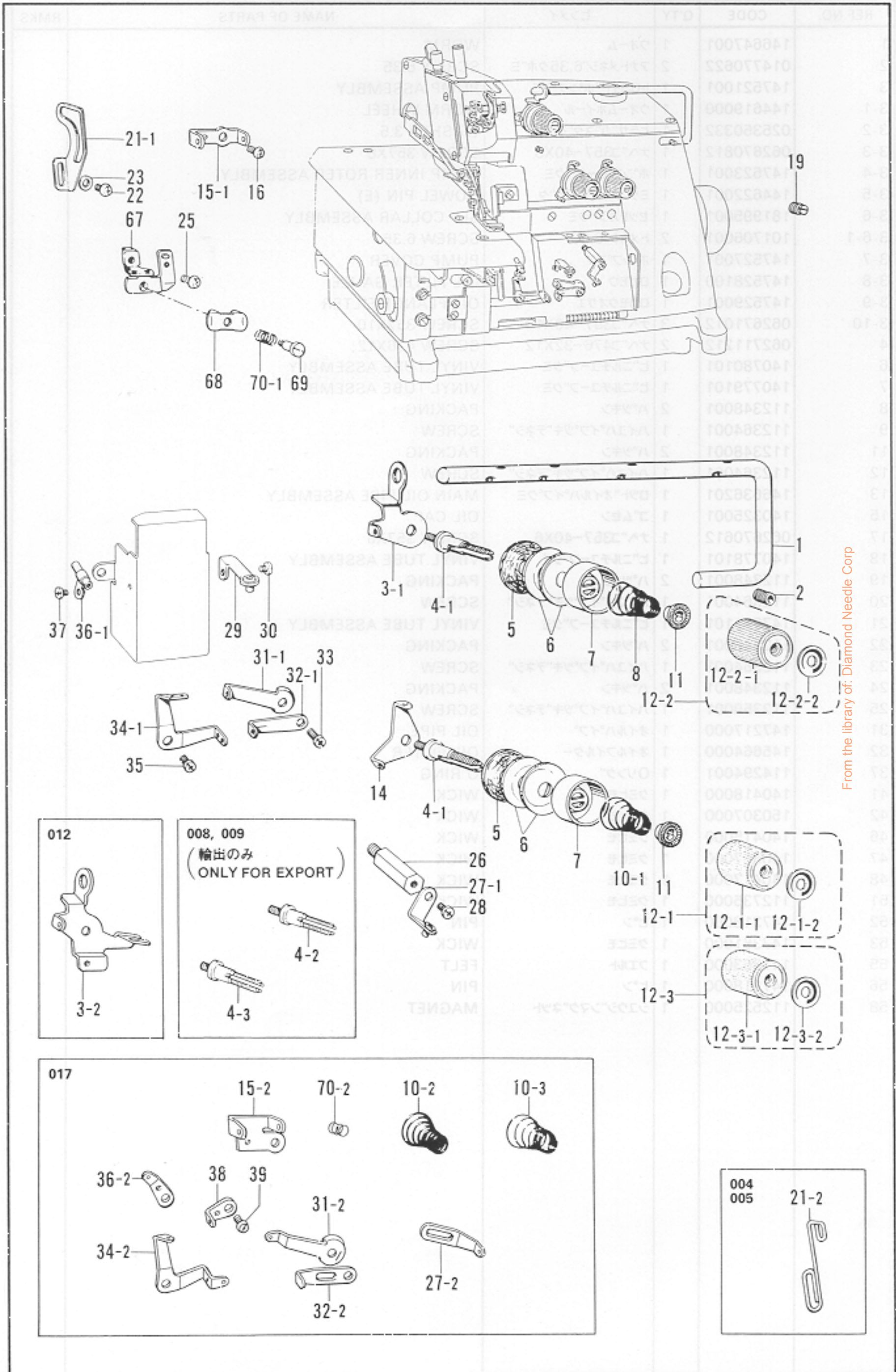

T. 糸調子関係/Thread tension/Faderspannung/Tension du fil/Tension del hilo

REF.NO.	CODE	Q'TY	ヒンメイ	NAME OF PARTS	RMKS
1	146648001	1	シユイトアンナイ	MAIN THREAD GUIDE	
2	014770622	1	アナトメネジ"6.35クホ"ミ	SCREW 6.35	
3-1	146649001	1	イトアンナイササエ	THREAD GUIDE SUPPORTER	
3-2	147485001	1	イトアンナイササエ <ハ"ックタックヨウ>	THREAD GUIDE SUPPORTER <FOR BACK TACKING>	
4-1	110820101	3	イトチヨウシホ"ウ	TENSION CONTROL STUD	
4-2	159574101	1	-----	TENSION CONTROL STUD <FOR RUFFLING>	
4-3	110820101	2	-----	TENSION CONTROL STUD <FOR RUFFLING>	
5	110832001	3	イトチヨウシサラフェルト	TENSION DISC FELT	
6	145446001	6	イトチヨウシサラ	TENSION DISC	
7	144103002	3	イトチヨウシサラオサエ	TENSION DISC WASHER	
8	144104001	1	ハリイトチヨウシハ"ネ	TENSION SPRING	
10-1	144110001	2	シタル-ハ"イトチヨウシハ"ネ	TENSION SPRING	
11	144105000	3	チヨウシハ"ネウエサ"カ"ネ	TENSION SPRING WASHER	
12-1	149568002	1	イトチヨウシナツクミ	THREAD TENSION CONTROL NUT ASSEMBLY	
12-1-1	149566001	1	イトチヨウシナツト	THREAD TENSION ADJUSTING NUT	
12-1-2	147049002	1	キヨウジ"ヤクハ"ン	TENSION INDICATING PLATE	
12-2	149568003	1	イトチヨウシナツクミ	THREAD TENSION CONTROL NUT ASSEMBLY	
12-2-1	149566001	1	イトチヨウシナツト	THREAD TENSION ADJUSTING NUT	
12-2-2	147049003	1	キヨウジ"ヤクハ"ン	TENSION INDICATING PLATE	
12-3	149568004	1	イトチヨウシナツクミ	THREAD TENSION CONTROL NUT ASSEMBLY	
12-3-1	149566001	1	イトチヨウシナツト	THREAD TENSION ADJUSTING NUT	
12-3-2	147049004	1	キヨウジ"ヤクハ"ン	TENSION INDICATING PLATE	
14	110813001	2	ハリイトアンナイ	NEEDLE THREAD GUIDE	
15-1	143757001	1	ハリイトアンナイA	NEEDLE THREAD GUIDE (A)	
16	062660412	1	ナヘ"コ318-40X4	SCREW 318X4	
19	151601002	1	トメネジ"4.37	SCREW 4.37	
21-1	144108001	1	ハリイトテンヒ"ン	NEEDLE THREAD TAKE-UP	
21-2	142201001	1	ハリイトテンヒ"ン <2ホ"イトヨウ>	NEEDLE THREAD TAKE-UP <2 THREADS>	
22	062660412	1	ナヘ"コ318-40X4	SCREW 318X4	
23	105248003	1	サ"カ"ネ	WASHER	
25	062670612	1	ナヘ"コ357-40X6	SCREW 357X6	
26	144111001	1	シタル-ハ"イトアンナイササエ	LOOPER THREAD GUIDE HOLDER	
27-1	146926002	1	イトアンナイクミ	UNDER LOOPER THREAD GUIDE ASSEMBLY	
28	062670612	1	ナヘ"コ357-40X6	SCREW 357X6	
29	146929001	1	ウフル-ハ"イトアンナイクミ	OVER LOOPER THREAD GUIDE ASSEMBLY	
30	062670612	1	ナヘ"コ357-40X6	SCREW 357X6	
31-1	146652001	1	ウフル-ハ"テンヒ"ンR	OVER LOOPER THREAD TAKE-UP (RIGHT)	
32-1	146653001	1	シタル-ハ"テンヒ"ンR	UNDER LOOPER THREAD TAKE-UP (RIGHT)	
33	062670812	1	ナヘ"コ357-40X8	SCREW 357X8	
34-1	146654001	1	ルー-ハ"テンヒ"ンL	LOOPER THREAD TAKE-UP (LEFT)	
35	062670612	1	ナヘ"コ357-40X6	SCREW 357X6	
36-1	142669002	1	イトアンナイハ"イプクミ	OVER LOOPER THREAD GUIDE PIPE ASSEMBLY	
37	060630312	1	ハ"イント"238-56X3	SCREW 2.38X3	
67	147344001	1	コチヨウシキトリツクダ"イクミ	NEEDLE THREAD GUIDE ASSEMBLY	
68	112300001	1	ハリイトオサエ	NEEDLE THREAD PRESSER	
69	112301001	1	タ"ンネジ"3.18	STUD SCREW 3.18	
70-1	112299001	1	ハリイトアンナイオシハ"ネ	SPRING	
<ソフトチェンヨウ/ FOR SOFT CHAIN>					
10-2	144104001	1	ハリイトチヨウシハ"ネ	TENSION SPRING	
10-3	144110001	1	シタル-ハ"イトチヨウシハ"ネ	TENSION SPRING	
15-2	S11670001	1	ハリイトアンナイA	NEEDLE THREAD GUIDE (A)	
27-2	S11672001	1	シタル-ハ"イトアンナイR	UNDER LOOPER THREAD GUIDE (RIGHT)	
31-2	S11673001	1	ウフル-ハ"テンヒ"ンR	OVER LOOPER THREAD TAKE-UP (RIGHT)	
32-2	S11674101	1	ルー-ハ"テンヒ"ン	LOOPER THREAD TAKE-UP	
34-2	S11675001	1	ルー-ハ"テンヒ"ンL	LOOPER THREAD TAKE-UP (LEFT)	
36-2	S11677001	1	ウフル-ハ"イトアンナイL	OVER LOOPER THREAD GUIDE (LEFT)	
38	S11676001	1	ウフル-ハ"イトアンナイM	OVER LOOPER THREAD GUIDE (MIDDLE)	
39	062670412	2	ナヘ"コ357-40X4	SCREW 357X4	
70-2	S11671001	1	ハリイトアンナイオシハ"ネ	SPRING	

From the library of: Diamond Needle Corp

Z. 付属品関係 / Accessories / Zubehör / Accessoires / Accesorios

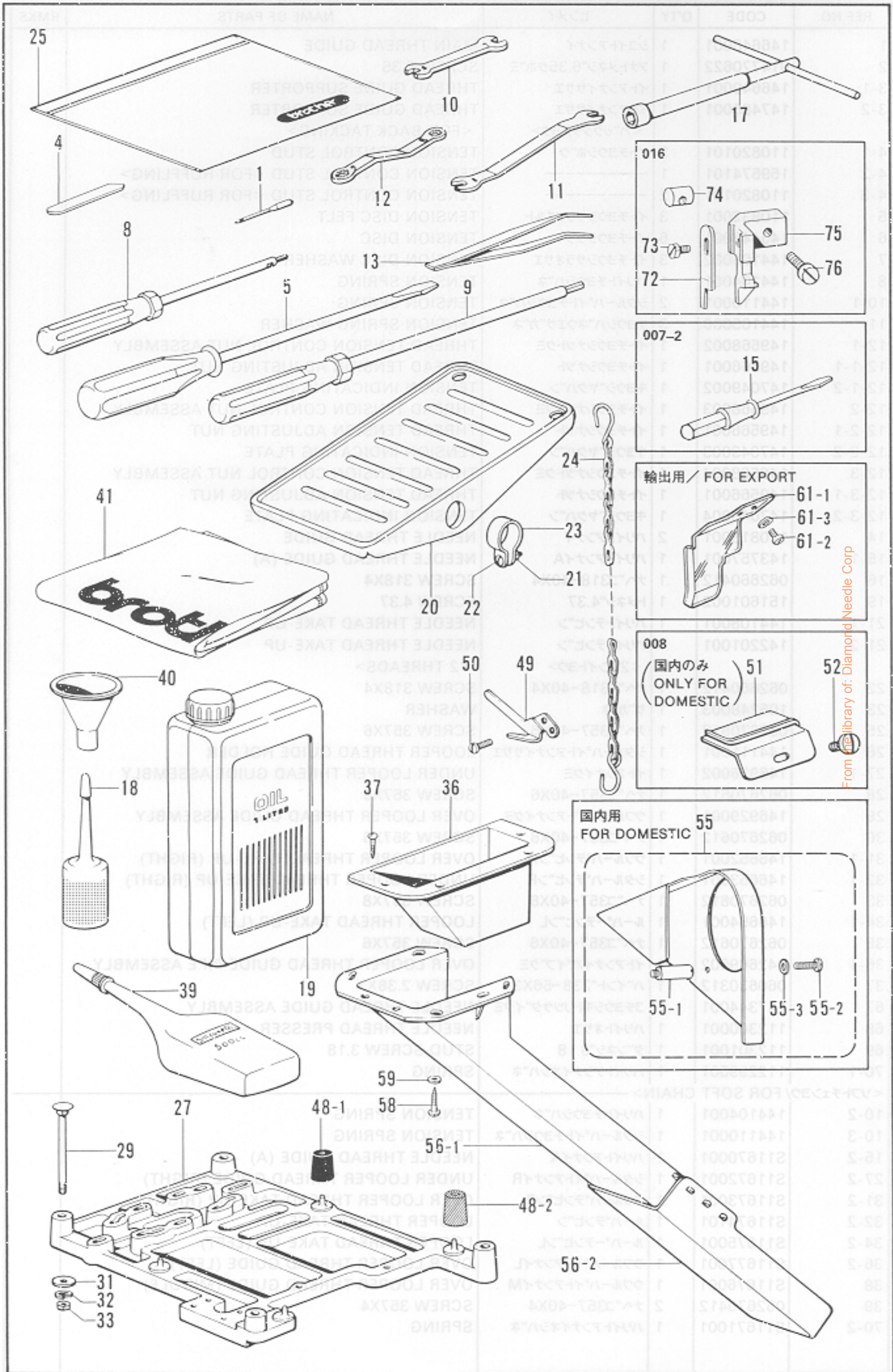

Z. 付属品関係 / Accessories / Zubehör / Accessoires / Accesorios

REF.NO.	CODE	Q'TY	ヒンメイ	NAME OF PARTS	RMKS
1	*	8	ミシンハリDCX1	NEEDLE DCX1	
4	112436001	1	シタメス	LOWER KNIFE	
5	1015721C1	1	ネジ"マワシ"5.5X190	SCREW DRIVER 5.5X190	
8	146700001	1	6カクホ"ウネジ"マワシ2	SCREW DRIVER 2	
9	149173001	1	6カクホ"ウネジ"マワシ3	SCREW DRIVER 3	
10	107779001	1	スパナ6X7	SPANNER 6X7	
11	143566001	1	スパナ8	SPANNER 8	
12	105343001	1	メカ"ネレンチ"8X9	WRENCH 8X9	
13	117466000	1	ピンセット	TWEEZERS	
15	148925001	1	ネジ"マワシ"2.3X40 <カーリング"ヨウ">	SCREW DRIVER 2.3X40 <FOR CURLING>	
17	140342001	1	ソケットレンチクミ	SOCKET WRENCH ASSEMBLY	
18	S06701000	1	ホ"リオイル"クミ	OILER ASSEMBLY	
19	145277105	1	オイルタンク	OIL TANK	
20	147893003	1	オサエアク"フミイタ	TREADLE PEDAL	
21	021400106	2	1シユナツト4	NUT 4	
22	062401406	2	ナヘ"コ"4X14	SCREW 4X14	
23	116016001	2	ヘ"タル"トメ	PEDAL STOPPER	
24	142262001	1	クサリ"フ"クミ	CHAIN (F) ASSEMBLY	
25	122991001	1	フソ"ク"ヒン"ホ"リ"フ"クロ	ACCESSORY BAG	
27	S03888000	1	トウフ"ウケ	HEAD PLATE	
29	210973001	4	カクネ"ボ"ルト"8X85	BOLT 8X85	
31	025080236	4	ヒラサ"カ"ネ"チ"ユウ"8	WASHER 8	
32	028080242	4	ハ"ネ"サ"カ"ネ"2-8	SPRING WASHER 2-8	
33	021080106	4	ナツト"1"シユ"8	NUT 8	
36	148430101	1	タ"スター"ト"ロツ"フ	DUSTER DROP	
37	031311302	4	マルモク"ネジ"3.1X13	SCREW 3.1X13	
39	S06704001	1	シリコン"オイル"	SILICONE OIL	
40	140759000	1	シ"ョー"ゴ"	FUNNEL	
41	144225002	1	トウフ"カ"ハ"ー	HEAD COVER	
48-1	147919001	1	ホ"ウ"シ"ン"ゴ"ム	CUSHION	
48-2	147919002	3	ホ"ウ"シ"ン"ゴ"ム	CUSHION	
49	140888001	1	カラ"スイ"メ"ス	TRIMMING KNIFE	
50	062660412	2	ナヘ"コ"318-40X4	SCREW 318X4	
51	144793000	1	キ"シ"ア"ン"ナイ	-----	
52	112751002	1	シ"メ"ネ"ジ"3.57	-----	
55	148348001	1	ヘ"ル"ト"カ"ハ"ー"ク"ミ	-----	
55-1	148042001	2	ヘ"ル"ト"カ"ハ"ー"ス"タ"ツ"ト"	-----	
55-2	062681012	2	ナヘ"コ"437-40X10	-----	
55-3	100645003	2	サ"カ"ネ	-----	
56	183161201	1	タ"スター"シ"ユ"ー"ト"ク"ミ	DUSTER SHOOT ASSEMBLY	
56-1	148431201	1	タ"スター"シ"ユ"ー"ト"L	DUSTER SHOOT (LARGE)	
56-2	148432001	1	タ"スター"シ"ユ"ー"ト"S	DUSTER SHOOT (SMALL)	
58	101118001	4	マルモク"ネジ"4.5X20	SCREW 4.5X20	
59	025050236	4	ヒラサ"カ"ネ"チ"ユウ"5	WASHER 5	
61	151017001	1	-----	EYE GUARD ASSEMBLY	
61-1	150550000	1	-----	EYE GUARD FOR OVERLOCK	
61-2	062660512	2	-----	SCREW 318X5	
61-3	025030232	2	-----	WASHER 3	
<ウマキ"ヨウ"/FOR OVER WINDING>					
72	144074000	1	ウ"フ"メ"ス	UPPER KNIFE	
73	144075001	1	ボ"ル"ト"3.57	BOLT 3.57	
74	148281101	1	ウ"フ"メ"ス"タ"キ"ナ"ツ"ト	NUT	
75	144073001	1	ウ"フ"メ"ス"タ"キ	UPPER KNIFE HOLDER	
76	107407003	1	シ"メ"ネ"ジ"4.37	SCREW 4.37	

※ 付属品の明細は変更することがあります。
 ※ The details of included accessories are subject to change.
 ※ Änderungen in der Aufstellung der Mitgelieferten Zubehöre sind vorbehalten.
 ※ Les détails des accessoires inclus sont sujets à des changements.
 ※ Los detalles de los accesorios incluidos pueden variar.

From the library of: Diamond Needle Corp

Z. 付属品関係 / Accessories / Zubehör / Accessoires / Accesorios

REF.NO.	CODE	Q'TY	ヒンメイ	NAME OF PARTS	RMKS
42	S02767101	1	イトタテダイクミ3THF	COTTON STAND ASSEMBLY 3THF	
42-1	150189002	1	ブラケット	COTTON STAND BASE	
42-2	S02773001	1	ブラケットネジセット	COTTON STAND BASE SCREW SET	
42-2-1	062060806	2	ナヘコ6X8	SCREW 6X8	
42-2-2	031452206	3	マルモク45X22	SCREW 45X22	
42-3	150172002	2	コラムパイプ	COLUMN PIPE	
42-4	150106002	1	コラムジョイントクミ	COLUMN JOINT ASSEMBLY	
42-4-1	062501406	2	ナヘコ5X14	SCREW 5X14	
42-4-2	021500106	2	1シユナツト5	NUT 5	
42-5	150174000	1	コラムキャップ	COLUMN CAP	
42-6	S02779001	1	スプールホルダー-3	SPOOL HOLDER 3	
42-7	S02782001	1	スプールネジセット3	SPOOL SHAFT SET 3	
42-7-1	150179002	3	スプールシクバ	SPOOL SHAFT (B)	
42-7-2	028050246	3	ハネサカネ2-5	SPRING WASHER 2-5	
42-7-3	021500106	5	1シユナツト5	NUT 5	
42-7-4	050503006	1	ナヘコヒラサ5X30	SCREW 5X30	
42-7-5	050501406	1	ナヘコヒラサ5X14	SCREW 5X14	
42-8	150180000	3	ウケサラ	SPOOL STAND BASE	
42-9	150182000	3	スプールマット	SPOOL MAT	
42-10	126863001	3	スプールのクッション	SPOOL CUSHION	
42-11	S02784001	1	ホルダーササエAセット	SPOOL HOLDER SUPPORTER (A) SET	
42-11-1	150188002	1	スプールのホルダーササエA	SPOOL HOLDER SUPPORTER (A)	
42-11-2	062501006	1	ナヘコ5X10	SCREW 5X10	
42-11-3	021500106	1	1シユナツト5	NUT 5	
42-11-4	031452206	1	マルモク45X22	SCREW 45X22	
42-12	S02788001	1	スレッドハンガークミ3	THREAD HANGER ASSEMBLY 3	
42-13	150145002	1	イトアンナイホルダークミ	THREAD GUIDE HOLDER ASSEMBLY	
42-13-1	150185002	1	イトアンナイホルダー	THREAD GUIDE HOLDER	
42-13-2	050503006	1	ナヘコヒラサ5X30	SCREW 5X30	
42-13-3	021500106	1	1シユナツト5	NUT 5	
42-14	142997001	1	イトアンナイ3	THREAD GUIDE 3	
42-15	S04109001	1	イトアンナイササエホウ	THREAD GUIDE SUPPORTER BAR	
42-16	138843001	1	ササエホウツキテ	JOINT	
42-17	014060632	2	アナトメ6X6クホミ	SCREW 6X6	
<オプション/OPTION PARTS>					
68	S03886001	1	フルサブマーシセット	FULL SUBMERGED SET	
68-1	153319001	1	トウフウケササエ	HEAD PLATE SUPPORTER	
68-2	153318101	3	カクネマルアタマホルト	BOLT	
68-3	211964001	1	カクネホルト8X55	BOLT 8X55	
68-4	017085502	1	ホルトM8X55	BOLT 8X55	
68-5	025080236	15	ヒラサガネチユウ8	WASHER 8	
68-6	028080242	5	ハネサカネ2-8	SPRING WASHER 2-8	
68-7	021080106	11	ナツト1シユ8	NUT 8	
68-8	S03889001	1	ダスターシュートササエ	DUSTER SHOOT SUPPORTER	
68-9	S03890001	1	ダスタートロツプ	DUSTER DROP	
68-10	062681212	6	ナヘコ437-40X12	SCREW 437X12	
68-11	025680232	6	ヒラサガネチユウ4.37	WASHER 4.37	
68-12	021680202	2	ナツト2シユ4.37	NUT 4.37	

From the library of: Diamond Needle Corp

※付属品の明細は変更することがあります。
 ※ The details of included accessories are subject to change.
 ※ Änderungen in der Aufstellung der Mitgelieferten Zubehöre sind vorbehalten.
 ※ Les détails des accessoires inclus sont sujets à des changements.
 ※ Los detalles de los accesorios incluidos pueden variar.

仕様別部品一覧表/DIFFERENT PARTS LIST/ZUBEHÖRLISTE/
LISTE DES PIÈCES ACCESSOIRES/LISTA DE PIEZAS ACCESORIAS

SUB CLASS	サンショウ パンゴウ REF.NO.	A-23	A-75	A-79	D-22	D-37-1		
	ヒンメイ PARTS シヨウ SPEC	ナヘ"コ437-40 X7 SCREW 437X7	オイルニガ"シグチ OIL CAP	シヨウラヘル LABEL	ミシンハリDCX1 NEEDLE DCX1	ハリタ NEEDLE PLATE		
001-3	イッパンジ"ヌイヨウ			146974001		146730001		
-4	(ウス.チュウアツ)	062680712	143196001	146974002	112297011	146731001		
-5	THIN.MEDIUM			146974003		146732001		
-6				146974054		146733001		
002-5	ハ"ルキーニット			146974004		146734001		
-6		↑	↑	146974005	112297014	146735001		
-7	BULKY KNIT			146974006		146736001		
003-3	スソヒキヨウ			146974007		146730001		
-4		↑	↑	146974008	112297009	146731001		
-5	BLING HEMMING			146974009		146732001		
004-3	スソヒキヨウ			146974010		146730001		
-4		↑	↑	146974011	↑	146731001		
	BLING HEMMING							
005-4	サー"シ"ング"			146974014		146731001		
-5	(2ホンイト)	↑	-----	146974015	112297014	146732001		
	SERGING (2 THREADS)							
006-4	サー"シ"ング"			146974017		146731001		
-5	(3ホンイト)	↑	-----	146974018	↑	146732001		
	SERGING (3 THREADS)							
007-2	カー"リ"ング"			146974057		-----		
-4		↑	143196001	146974056	112297011	148314001		
	CURLING							
008-5	ラフ"リ"ング"					-----		
		↑	-----	146974019	↑	146737001		
	RUFFLING							
009-5	ハイ"ヒ"ング"					-----		
	ラフラー	↑	-----	146974020	↑	↑		
	RUFFLING (W/PIPING)							

From the library of: Diamond Needle Corp

	サンショウ ハンゴウ REF.NO.	A-23	A-75	A-79	D-22	D-37-1		
SUB CLASS	ヒンメイ PARTS	ナヘ"コ437-40 X7 SCREW 437X7	オイルニガ"シク"チ OIL CAP	シヨウラヘル LABEL	ニシンハリDCX1 NEEDLE DCX1	ハリイタ NEEDLE PLATE		
	シヨウ SPEC							
010-3	テーピング			146974023		146730001		
-4		062680712	143196001	146974022	112297011	146731001		
-5	TAPING			146974021		146732001		
011-5	ハルキーニット			146974024		146734001		
-6	テーピング BULKY KNIT TAPING	↑	↑	146974025	112297014	146735001		
012-3	バックタッキング			146974042		S11106001		
-4		-----	↑	146974043	112297011	S11107001		
-5	BACK- TACKING			146974044		S11108001		
016-4	ウフマキヨウ			146974069		S06006001		
-5	OVER WINDING	062680712	↑	146974070	↑	S06007001		
017-3	ソフトチェーン			146974075		146730001		
-4		-----	↑	146974076	↑	146731001		
-5	SOFT CHAIN			146974077		146732001		

From the library of: Diamond Needle Corp

	サンショウ ハンゴウ REF.NO.	F-67	F-68	F-69	G-8-1	G-9-1		
SUB CLASS	ヒンメイ PARTS	シュオクリハ(クミ)	サト"ウオクリハ" (クミ)	ホジ"ヨオクリハ"	ウフメス	ホルト3.57		
	シヨウ SPEC	MAIN FEED DOG (ASSEMBLY)	DIFFEREN- TIAL FEED DOG (ASSEMBLY)	CHAIN FEED DOG	UPPER KNIFE	BOLT 3.57		
001-3	イッパ"ンジ"ヌイヨウ							
-4	(ウス.チュウアツ)	S09348101	S09349101	S13428001	144074000	144075001		
-5	THIN.MEDIUM							
-6								
002-51	ハ"ルキーニット				144074000	144075001		
-52		146745101	146750101	S13429001	-----	-----		
-6	BULKY KNIT				-----	-----		
-7					-----	-----		
003-3	スソヒキヨウ							
-4		S09348101	S09349101	S13428001	144074000	144075001		
-5	BLING HEMMING							
004-3	スソヒキヨウ							
-4		↑	↑	↑	↑	↑		
	BLING HEMMING							
005-4	サー"ジ"ング							
-5	(2ホンイト)	S09348101	S09349101	↑	↑	↑		
	SERGING (2 THREADS)							
006-4	サー"ジ"ング							
-5	(3ホンイト)	↑	↑	↑	↑	↑		
	SERGING (3 THREADS)							
007-2	カー"リ"ング	(153549001)	(S13418001)	S13432001				
-4		S09348101	S09349101	S13428001	↑	↑		
	CURLING							
008-5	ラフ"リ"ング							
		S13188001	S13417001	S13429001	↑	↑		
	RUFFLING							
009-5	ハイ"ピ"ング							
	ラフ"ラ"	S13189001	↑	S13431001	↑	↑		
	RUFFLING (W/PIPING)							

From the library of: Diamond Needle Corp











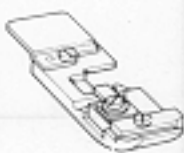



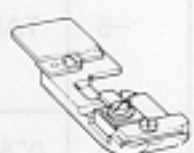









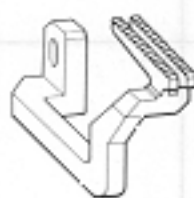

	サンショウ ハンゴウ REF.NO.	F-67	F-68	F-69	G-8-1	G-9-1		
SUB CLASS	ヒンメイ PARTS	シュオクリハ MAIN FEED DOG	サトウオクリハ DIFFEREN- TIAL FEED DOG	ホジョオクリハ CHAIN FEED DOG	ウワメス UPPER KNIFE	ホルト3.57 BOLT 3.57		
	ショウ SPEC							
010-3	テーピング							
-4		S09348101	S09349101	S13428001	144074000	144075001		
-5	TAPING							
011-5	ハルキーニット							
-6	テーピング BULKY KNIT TAPING	146745101	146750101	S13429001	-----	-----		
012-3	バックタッキング		S13424001					
-4		S13191001	↑	S13428001	144074000	144075001		
-5	BACK- TACKING		S13423001					
016-4	ウワマキヨウ							
-5	OVER WINDING	S09348101	S13422001	↑	-----	-----		
017-3	ソフトチェーンヨウ							
-4		↑	S09349101	↑	144074000	144075001		
-5	SOFT CHAIN							

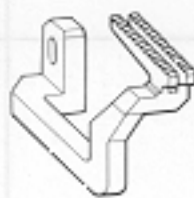





















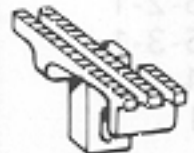



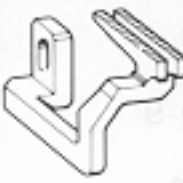

From the library of: Diamond Needle Corp

	サンショウ ハンゴウ REF.NO.	G-25	G-26-1	G-27-1	Q-13	Z-1		
SUB CLASS	ヒンメイ PARTS シヨウ SPEC	ウフメスタキナット NUT	ウフメスタキ UPPER KNIFE HOLDER	シメネジ4.37 SCREW 4.37	ウフルーパキコウクミ OVER LOOPER ASSEMBLY	ミシンハリDCX1 NEEDLE DCX1		
001-3	イッパンシメイヨウ							
-4	(ウス.チュウアツ)	148281101	144073001	107407003	146603301	112297011		
-5	THIN.MEDIUM							
-6								
002-51	ハルキーニット		144073001	107407003				
-52		↑	-----	-----	146611301	112297014		
-6	BULKY KNIT		-----	-----				
-7			-----	-----				
003-3	スリヒキヨウ							
-4		↑	144073001	107407003	146603301	112297009		
-5	BLING HEMMING							
004-3	スリヒキヨウ							
-4	BLING HEMMING	↑	↑	↑	↑	↑		
005-4	サージ"ング"							
-5	(2ホニイト) SERGING (2 THREADS)	↑	↑	↑	↑	112297014		
006-4	サージ"ング"							
-5	(3ホニイト) SERGING (3 THREADS)	↑	↑	↑	↑	↑		
007-2	カーリング"							
-4	CURLING	↑	↑	↑	↑	112297011		
008-5	ラフリング"							
	RUFFLING	↑	↑	↑	↑	↑		
009-5	ハイヒ"ング"							
	ラフラー RUFFLING (W/PIPING)	↑	↑	↑	↑	↑		

From the library of: Diamond Needle Corp

ゲージ部品/GAUGE PARTS/TEILE DER LEHRE/
PIECES DE JAUGE/PIEZAS DE CALIBRE

サブ クラス Sub-Class	一般地縫用 (薄物、中厚物) Thin (Medium)	バルキーニット用 Bulky Knit	裾引用 Bling Hemming	裾引用 Bling Hemming	サージング用 (2本針) Serging (Two threads)	サージング用 (1本針) Serging	カーリング用 Curling
品名 Name of Parts	001-3 -4 -5 -6	002-5 -6 -7	003-3 -4 -5	004-3 -4	005-4 -5	006-4 -5	007-2 -4
オサエクミ Presser Foot Assembly	 156558-101 156562-101	 S03828-001 154974-001	 146890-201		 154970-201		 153547-101 154976-101
ハリイタ Needle Plate	 146730-001 146731-001 146732-001 146733-001	 146734-001 146735-001 146736-001	 146730-001 146731-001 146732-001	 146730-001 146731-001	 146731-001 146732-001		 153544-001  148114-001
シュオクリバ(クミ) Main Feed Dog (Assembly)	 S09348-101	 146745-101		 S09348-101			 (153549-001)  S09348-101
サドウオクリバ (クミ) Differential Feed Dog (Assembly)	 S09349-101	 146750-101		 S09349-101			 (S13418-001)  S09349-101
ホジョオクリバ Chain Feed Dog	 S13428-001	 S13429-001		 S13428-001			 S13432-001  S13428-001

サブ クラス Sub-Class	ラフリング用 Ruffling	ラフリング用 (パイピング付) Ruffling (W/piping)	テーピング用 Taping	バルキーニット テーピング用 Bulky Knit Taping	バックタッキング用 Back-tacking	ウワマキ用 Over Winding	ソフトチェーン用 Soft Chain
品名 Name of Parts	008-5	009-5	010-3 -4 -5	011-5 -6	012-3 -4 -5	016-4 -5	017-3 -4 -5
オサエクミ Presser Foot Assembly	 154971-001	 154975-001	 159367-001  156560-001		 S11115-101	 S06008-001	 156558-101
ハリイタ Needle Plate	 146737-001		 146730-001 146731-001 146732-001	 146734-001 146735-001	 S11106-001 S11107-001 S11108-001	 S06006-001 S06007-001	 146730-001 146731-001 146732-001
シュオクリバ Main Feed Dog	 S13188-001	 S13189-001	 S09348-101	 146745-101	 S13191-001		 S09348-101
サドウオクリバ Differential Feed Dog	 S13417-001		 S09349-101	 146750-101	 S13424-001 S13423-001	 S13422-001	 S09349-101
ホジョオクリバ Chain Feed Dog	 S13429-001	 S13431-001	 S13428-001	 S13429-001		 S13428-001	

From the library of: Diamond Needle Corp